

BIG
BIG DAISHOWA

BIG-PLUS [®] **TOOLING SYSTEM** **PAT.**
US Patent No. 5352073

Patented U.S.A., CANADA, GERMANY, U.K., FRANCE,
ITALY, SOUTH KOREA & TAIWAN

BIG DAISHOWA SEIKI CO LTD

CATALOG No. **EXi48-4**

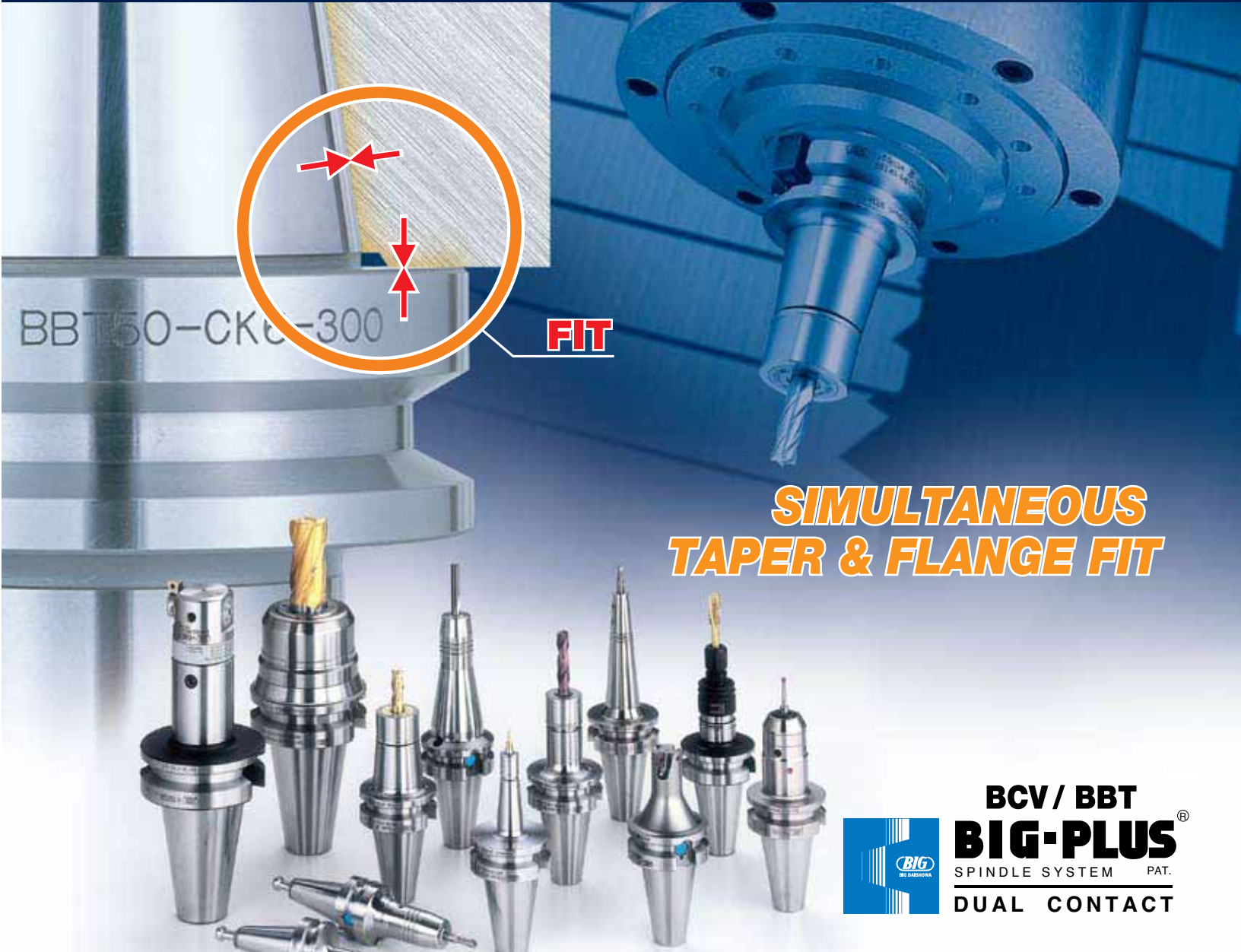

**SIMULTANEOUS
TAPER & FLANGE FIT**

BCV / BBT
BIG-PLUS [®]
SPINDLE SYSTEM **PAT.**
DUAL CONTACT

Simultaneous fit system surpasses all other spindle concepts while offering interchangeability with existing machines and tool holders.

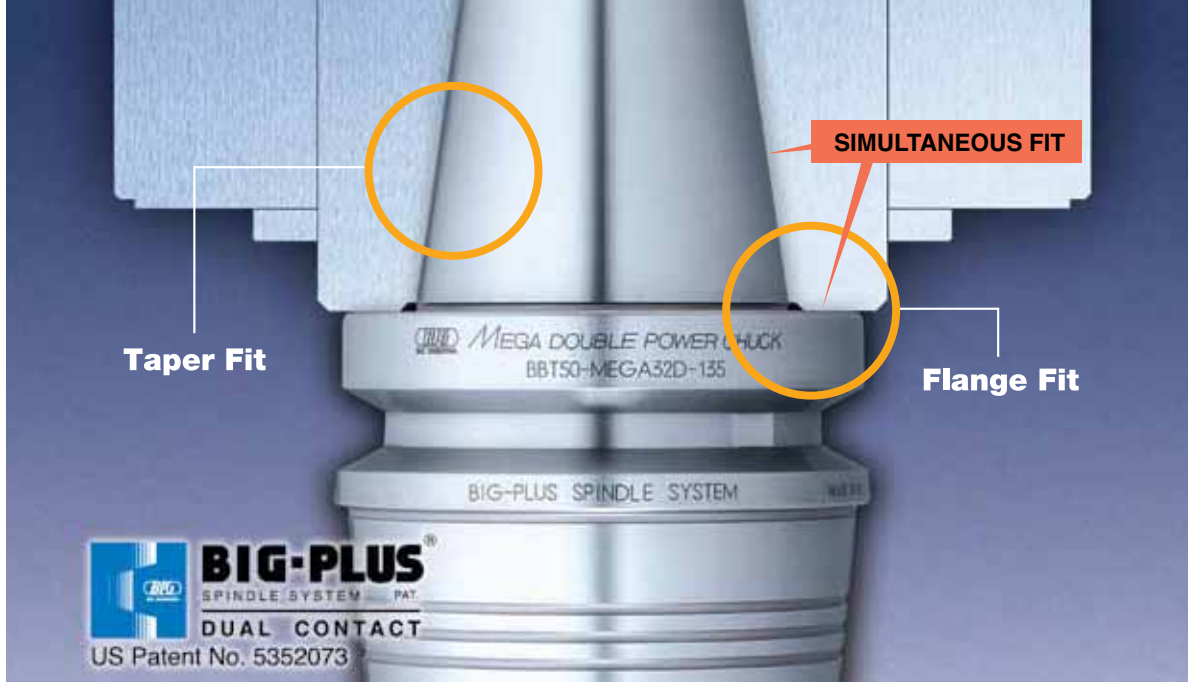

CAT & BT DUAL CONTACT SYSTEM MAINTAINS INTERCHANGEABILITY W/ EXISTING STANDARD MACHINES



- Higher rigidity due to larger contact diameter
- Improved ATC repeatability
- Elimination of axial movement at high speeds

INDEX

PG. 1-4	BIG-PLUS® Spindle System Concept	PG. 26-29	End Mill Holder, Shell Mill Adapter, Shrink Fit Holder, Blank Bar, ER Collet Chuck
PG. 5-6	Application Examples	PG. 30-34	Indexable Insert End Mill (Fullcut Mill)
PG. 7-10	System Overview	PG. 35-36	Modular Systems (Kaiser, ABS, Capto Holders)
PG. 11-12	Collet Chuck (Mega Micro Chuck)	PG. 37-45	Turning Tools for MTC's
PG. 13-19	Collet Chuck (Mega New Baby Chuck)	PG. 46-47	Gauges and Measuring Equipment
PG. 20-22	Collet Chuck (Mega E Chuck)	PG. 48	Pullstud Bolts
PG. 23-25	Milling Chuck (Mega Double Power Chuck)	PG. 49	Accessory Tools

BASIC CONCEPT

The BIG-PLUS® Spindle System is based on the most current available standards in MAS403, DIN69871 and ASME B5.50-1994. In this system, both the taper and face of the machine spindle and tool holder are fit.

A conventional steep taper tool holder is supported on a reference diameter called the gauge face. On the contrary, a BIG-PLUS® tool holder is supported on the flange face, which brings about higher rigidity and precision than a conventional tool holder.

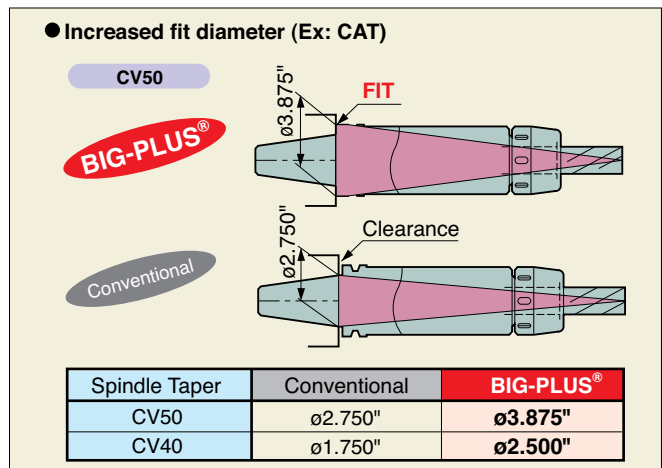

WORKING PRINCIPLE

The **BIG-PLUS**[®] Spindle System utilizes elastic deformation of the machine spindle and achieves simultaneous fit of both the taper and flange face.

Before clamping, although tapers are fit, faces have small clearance and are not fit at this point. When the tool holder is pulled in by the clamping mechanism, the machine spindle expands by elastic deformation and the faces are fit, which completes simultaneous fit between both the taper and face.

Reference Data

Spindle Taper	Pulling Force	Axial Movement
#40	1,760 lbs	.0008"
#50	4,410 lbs	.0008"

The above pulling force and axial movement depends on each model of machine.

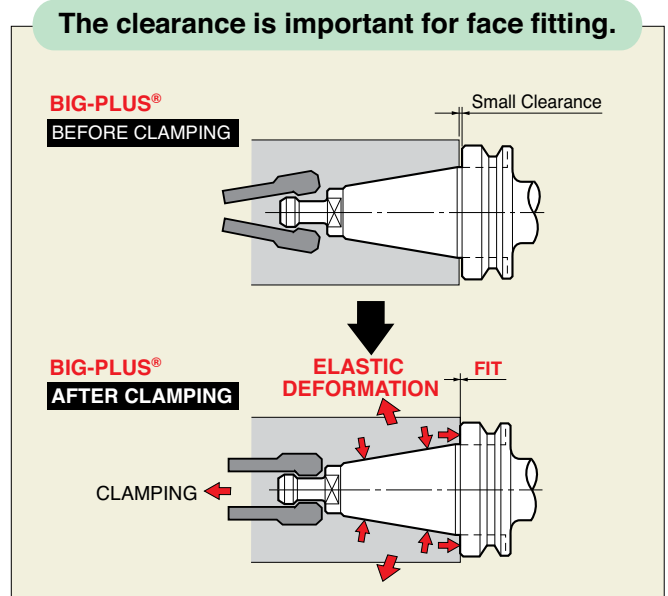

Q Can existing machines and tool holders be used?

A Yes, existing machines and tool holders can be used in **BIG-PLUS**[®] Spindle System machines and tool holders. When a new machine with the **BIG-PLUS**[®] Spindle System is introduced, existing tool holders can be used. It is not necessary to purchase all new tool holders. Therefore, it is possible to save cost to introduce simultaneous fit tool holders.

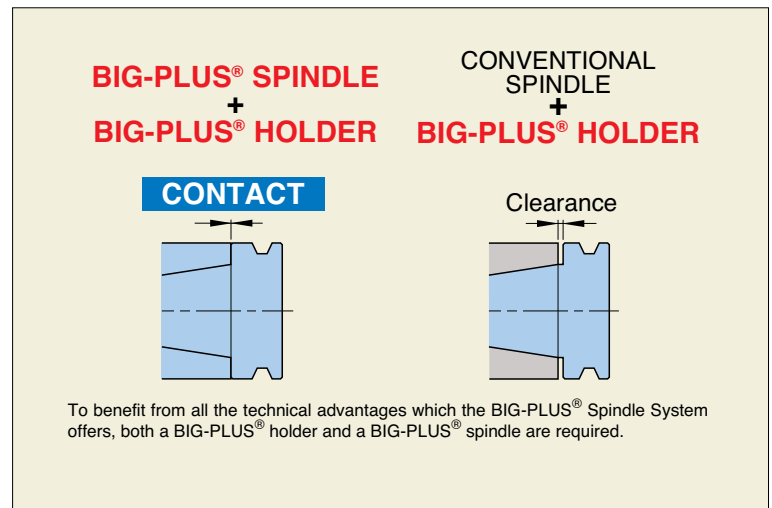

Q Are new accessories required?

A No, they are not required. Although other simultaneous fit systems require exclusive new accessories, the **BIG-PLUS**[®] Spindle System uses existing accessories such as a presetter and tool holder fixture as it is based on a conventional steep taper shank. Therefore, no extra cost is needed.

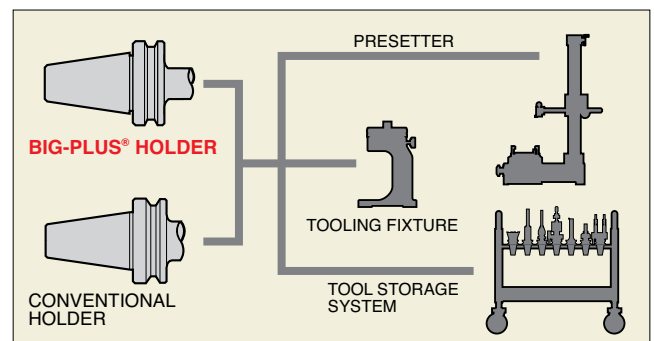

Q

Is there any effect on the life of a machine spindle and tool holder?

A

Simultaneous fit of both the taper and face prevents vibration from heavy or high speed cutting and discoloration on the taper (called fretting corrosion).



Q

What benefit can be expected at high spindle speeds?

A

At high speed rotation, a machine spindle expands due to centrifugal force and heat. Then, a tool holder is pulled into the machine spindle.

On the contrary, a BIG-PLUS® tool holder is not pulled in even at high speed rotation as the flange face fits the machine spindle nose. Then, variation of projection length in Z-axis is minimized. (Variation due to heat exists)

● Z-axis movement during rotation (Ex: CV40)

BIG-PLUS®

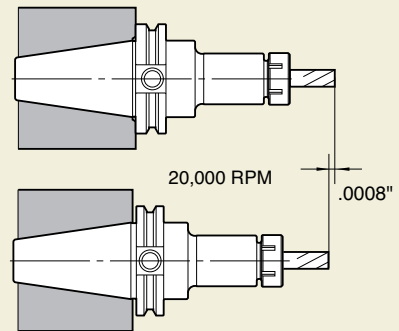

CONVENTIONAL

● BIG-PLUS®
■ CONVENTIONAL

Effect by thermal deformation is included.

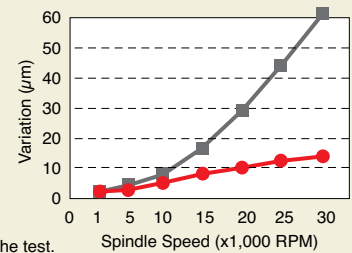

A vertical machine is used in the test.

Q

What effect will there be on machining results?

A

Rigidity is enhanced by simultaneous fit of both the taper and face. There are excellent effects on heavy or high speed cutting, deep or large diameter boring and especially using a cutting tool with a long projection length.

● Comparison of deflection

CV40

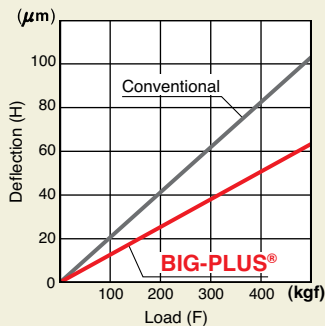
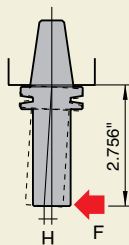

Deflection of a machine spindle is included. A vertical machine is used in the test.

CV50

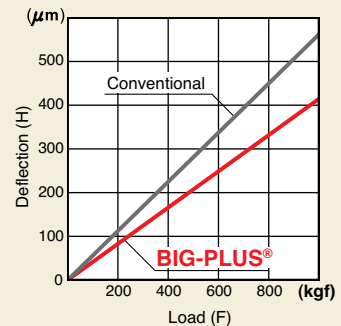
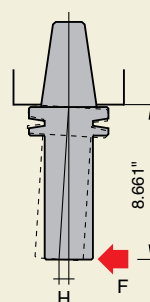

Deflection of a machine spindle is included. A vertical machine is used in the test.

Q What influence is there on ATC (Automatic Tool Change) repeatability?

A Since a BIG-PLUS® tool holder is rigidly supported on both the taper and face, higher repeatability at ATC can be achieved. This brings about many good effects such as lower T.I.R. and stable precision finish boring.

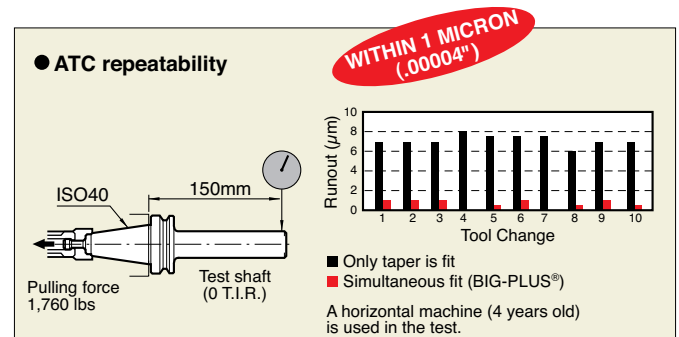

Q Is there any problem using BIG-PLUS® tool holders on different BIG-PLUS® machines?

A No, there is no problem. The BIG-PLUS® Spindle System is strictly controlled in dimensions of a machine spindle as well as a tool holder. In order to guarantee simultaneous fit between both the taper and face, the dimensions are measured by an exclusive high tolerance gauge and measuring devices. Full interchangeability exists between all BIG-PLUS® machine spindles and BIG-PLUS® tool holders.

For optimal performance, be sure to only use tool holders marked with "BIG-PLUS SPINDLE SYSTEM".

Strict gauge controls for BIG-PLUS® spindles are maintained by the licensed Machine Builders.

[Gauge and measuring devices for machine spindle]

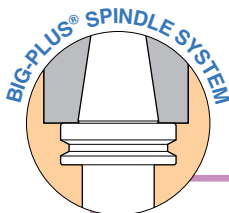
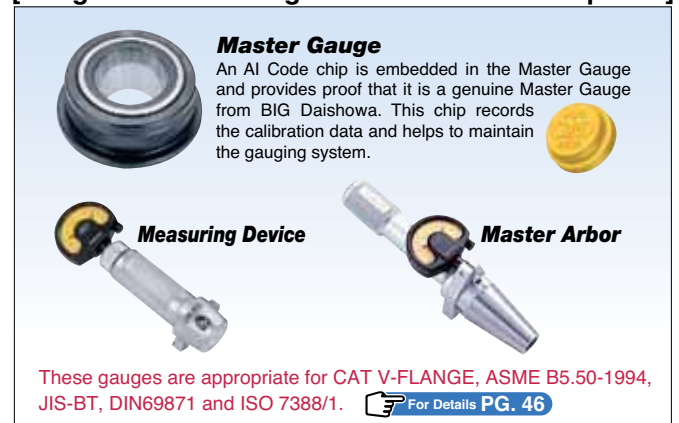

MACHINE BUILDERS

The BIG-PLUS® Spindle System is offered by many of the world's leading manufacturers of machining centers. Some of the machine and spindle builders who have produced BIG-PLUS® spindles are as follows:

ASA TECH, ADVANCED MACHINE, ALEX-TECH, ANCA, ARES, BERG SPANNTTECHNIK, BROTHER, CHEVALIER, CHUO-SEIKI, CITIZEN, COLGAR, CROSS HÜLLER EX-CELL-O LAMB, D.S.TECHNOLOGIE, DAH LIH, DIXI, DMG, DOOSAN, EGURO, ENSHU, FANUC, FOREST-LINÉ, FPT, FUJI SEIKI, GIDDINGS & LEWIS, HNK, HOMMA, HORKOS, HOWA, HWACHEON, IBAG, IKEGAI, IMARI, INOUE KOSOKU KIKAI, JOHNFORD, JTEKT, KARATS, KASHIFUJI, KITAMURA, KIWA, KOMATSU, KOMATSU NTC, KONDIA, KOYO, KURAKI, LAZZATI, MAGNIX, MAKINO, MAKINO SEIKI, MANDELLI, MATSUURA, MAZAK, MECTRON, MILLTRONICS, MITSUBISHI, MITSUBOSHI KOGYO, MITSUI SEIKI, MORI SEIKI, MOTOKUBO, NEO, NICOLÁS CORREA, NIIGATA, NIPPON BEARING, NISHIJIMAX, NISSIN-MFG, NOMURA, NORTHLAND TOOL, NSK, NSS, OBATAKE, OHTORI, OKK, OKUMA, O-M, OMLAT, PAMA, PMC, QUASER, REIDEN, ROKU ROKU, ROYAL, SAJO, SEMPUCO, SETCO, SHAN RONG, SHODA, SHW, SKG, SNK, SODICK, SORALUCE, STARRAGHECKERT, STUDER, SUGINO, TAJMAC-ZPS, TAKISAWA, TANABE, TOPPER, TOS VARNSDORF, TOSHIBA, TOYO SEIKI, TSUGAMI, UTSUNOMIYA, VICTOR TAICHUNG, WALDRICH COBURG, WIA, YAMASAKI GIKEN, YAMASHINA, YASDA, YCM, YU HUNG

[As of July 2009]

APPLICATION EXAMPLES

END MILLING APPLICATIONS

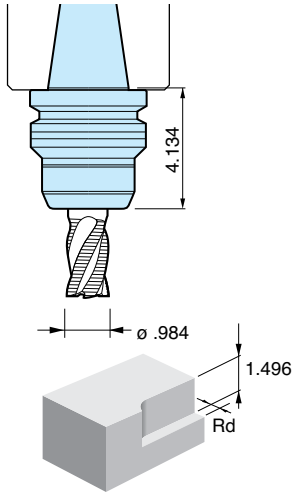

#50 Taper

Increased Rigidity

■ CUTTING CONDITIONS

MACHINE TOOL	BBT50 Vertical Machining Center
TOOL HOLDER	BBT50-MEGA25D-105 BT50 Milling chuck by other manufacturer
CUTTER	ø.984" 4-flute roughing end mill
WORK MATERIAL	1055 (Carbon Steel)
REVOLUTION	701 RPM
CUTTING SPEED	180 SFM
FEED RATE	16.54 IPM .0059 IPT

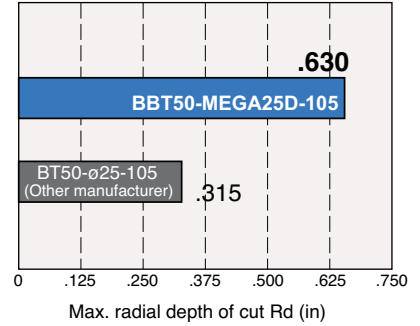

■ RESULT

Increased rigidity permits a 2x greater radial depth of cut.

FACE MILLING APPLICATIONS

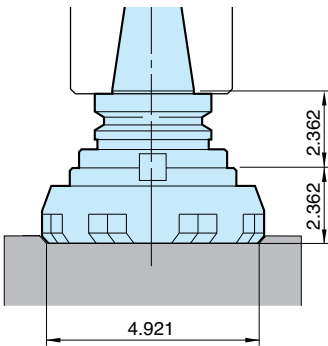

#40 Taper

Increased Rigidity

■ CUTTING CONDITIONS

MACHINE TOOL	BBT40 Horizontal Machining Center
TOOL HOLDER	BBT40-FMA38.1-60 BT40-FMA38.1-60
CUTTER	ø4.921" (6 cutting edges)
WORK MATERIAL	1049 (Carbon Steel)

REVOLUTION	356 RPM
CUTTING SPEED	459 SFM
FEED RATE	8.43 IPM .0039 IPT
CUTTING WIDTH	4.921"

■ RESULT

Rigidity increased. Cutting efficiency is increased to 1.4x greater than a conventional holder.

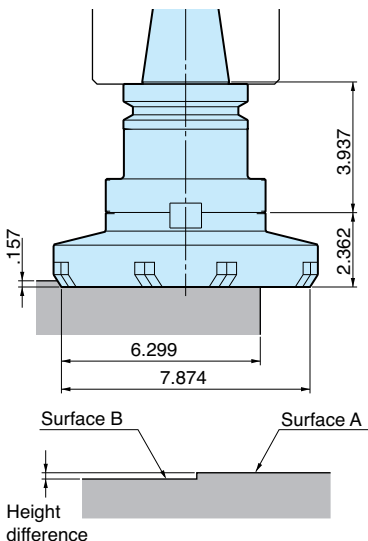
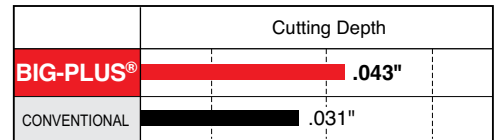

#50 Taper

Improved Accuracy

■ CUTTING CONDITIONS

MACHINE TOOL	BBT50 Vertical Machining Center
TOOL HOLDER	BBT50-FMA47.625-100 BT50-FMA47.625-100
CUTTER	ø7.874" (10 cutting edges)
WORK MATERIAL	304 (Stainless Steel)

REVOLUTION	320 RPM
CUTTING SPEED	656 SFM
FEED RATE	50.39 IPM .0157 IPT

■ RESULT

Increased rigidity eliminates height difference on workpiece surface.

	Height difference on surfaces A and B
BIG-PLUS®	None
CONVENTIONAL	In the order of 0.1mm (.004")

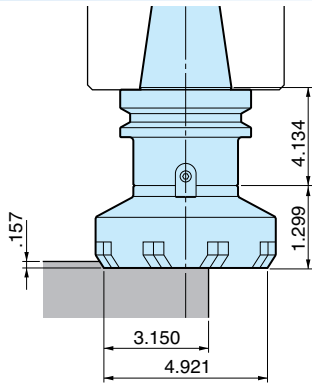

#50 Taper

Improved Tool Life

CUTTING CONDITIONS

MACHINE TOOL	BBT50 Horizontal Machining Center
TOOL HOLDER	BBT50-FMA38.1-105
CUTTER	ø 4.921" (6 cutting edges)
WORK MATERIAL	SCNCRM2B (JIS Low Alloy Steel)

REVOLUTION	382 RPM
CUTTING SPEED	492 SFM
FEED RATE	28.86 IPM
	.0126 IPT

RESULT

Cutting efficiency increased 1.8x, and tool life was prolonged more than 3x.

BORING APPLICATIONS

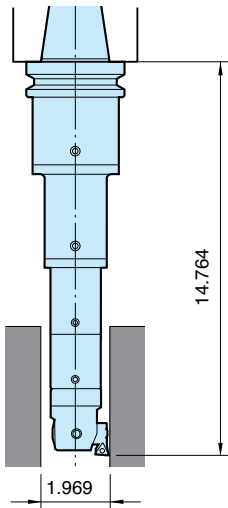

#50 Taper

Increased Rigidity

CUTTING CONDITIONS

MACHINE TOOL	BBT50 Horizontal Machining Center
TOOL HOLDER	11.368.374 (BIG-PLUS®) +10.332.760 10.326.374 +10.332.640 +10.331.440 +10.310.401
INSERT	CT51 (Nose R.016")
WORK MATERIAL	1049 (Carbon Steel)

REVOLUTION	1,146 RPM
CUTTING SPEED	410 SFM
FEED RATE	3.62 IPM
	.0031 IPR
BORING DIAMETER	1.97"
D.O.C.	.010"

RESULT

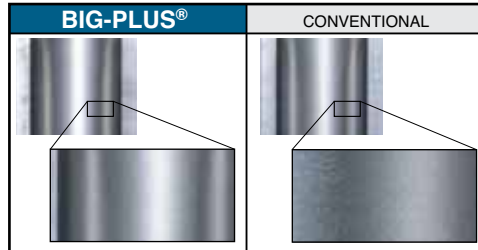

A conventional holder caused chattering and left marks like scales. The BIG-PLUS® holder enabled cutting without problems.

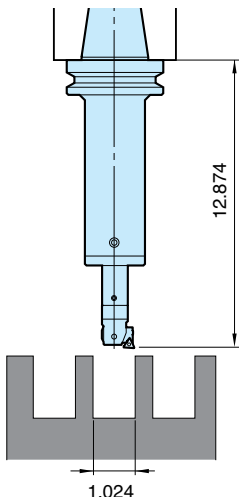

#50 Taper

Improved Accuracy

CUTTING CONDITIONS

MACHINE TOOL	BBT50 Vertical Machining Center
TOOL HOLDER	11.368.366 (BIG-PLUS®) +10.332.621 10.326.366 +10.310.201
INSERT	CT51 (Nose R.008")
WORK MATERIAL	1049 (Carbon Steel)

REVOLUTION	2,200 RPM
CUTTING SPEED	591 SFM
FEED RATE	6.06 IPM
	.0028 IPR
BORING DIAMETER	1.024"
D.O.C.	.008"

RESULT

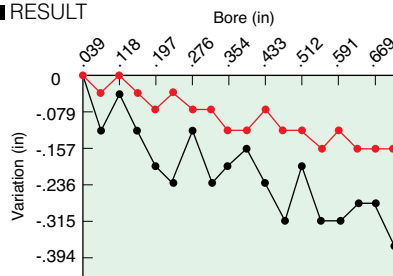

Stable bore diameter is achieved as a result of the superior repeatability during automatic tool changing.

VARIATION (INCLUDING CHIP WEAR)	
BIG-PLUS®	.00016"
CONVENTIONAL	.00035"

• Variation is 0 for the first hole.
• ATC was conducted for each hole and a total of 18 holes were bored.

MEGA CHUCK® SERIES PAT.

ORIGINAL DESIGN OF NOTCH-FREE NUT PREVENTS VIBRATION AND NOISE

Vibration at high speeds is eliminated by a notch-free nut which offers superior balance and concentricity. This ideal nut design not only eliminates whistling noise and coolant splattering, but also assures increased strength of the nut itself.

World's first

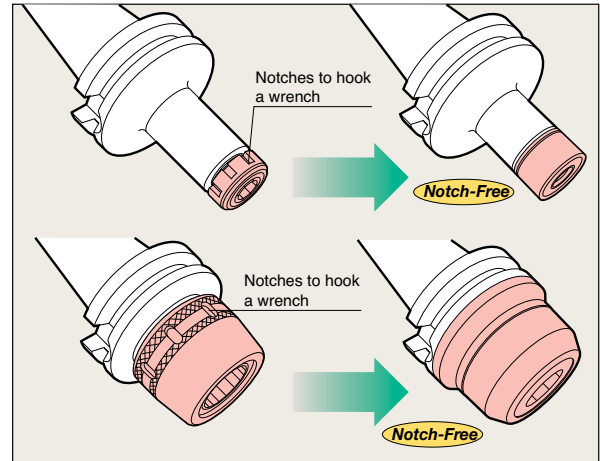

EASY AND FIRM CLAMPING WITH THE MEGA WRENCH

The Mega Wrench has a uniquely designed one way clutch system with a roller bearing and ratchet function and is capable of safely and evenly applying force on the entire nut periphery.

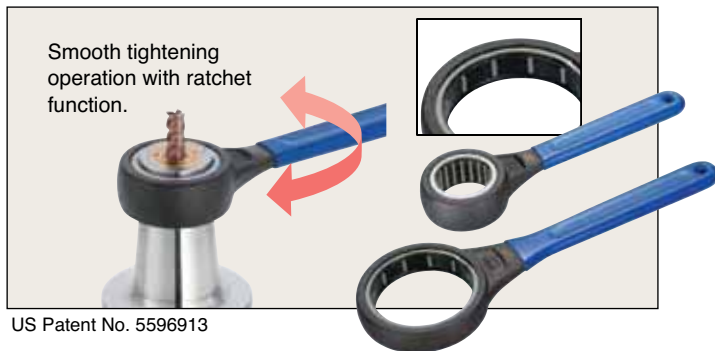

BIG-PLUS® CAT SHANKS WITH COOLANT BORES IN ACCORDANCE TO DIN 69871/FORM B

The Mega Chuck Series can supply coolant through both the center and flange. (Exception: Mega Micro Chuck)

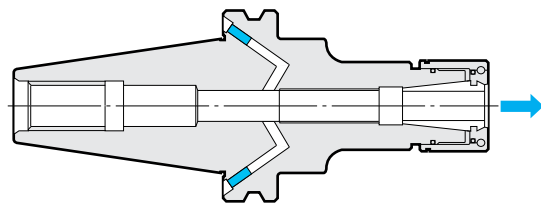

MEGA MICRO CHUCK® PAT.

PG. 11

Clamping Range: $\varnothing.018'' - \varnothing.238''$

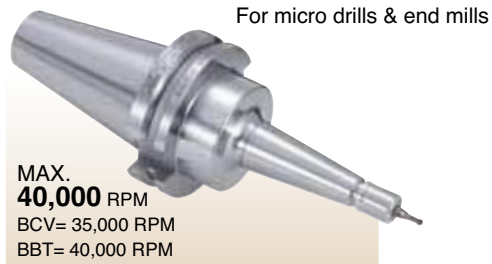

"Taper Type" For Micro End Milling

The super slim taper design of the Mega Micro Chuck makes it suitable for micro end mills.



MEGA MICRO COLLET

Interval of clamping dia. is .004". Just fitting for micro cutting tools.

Collet Class	T.I.R.		.00004" .00012"
	At nose	At end of test bar	
AA	Within .00004"	Within .00012"	

MEGA NEW BABY CHUCK® PAT. PG. 13 US Patent No. 4817972

Clamping Range: $\phi.010'' - \phi.787''$



For end mills, drills, taps, reamers, etc.

MAX.
40,000 RPM
BCV= 35,000 RPM
BBT= 40,000 RPM

Guaranteed accuracy of .00004" T.I.R. at the collet nose

NEW BABY COLLET

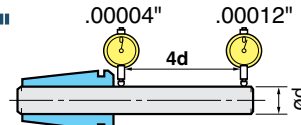

Collet Class	T.I.R.	
	At nose	At end of test bar
AA	Within .00004"	Within .00012"

For High Pressure Coolant Supply

Nut with seal for Mega New Baby Chuck. Performance of the seal improves with higher coolant pressure.

MEGA PERFECT SEAL PAT.

US Patent No. 5975817

MAX. COOLANT PRESSURE
1,000 PSI

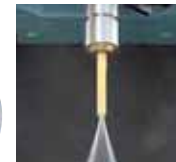

Through Tools



Jet Through

MEGA E CHUCK® PAT. PG. 20 US Patent No. 4817972

Clamping Range: $\phi.125'' - \phi.500''$

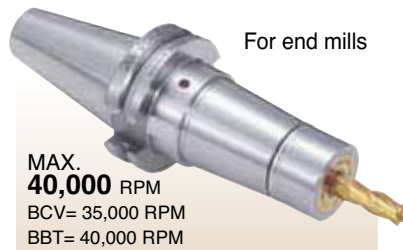

For end mills

Slit-Through Coolant

Coolant is securely directed to the cutting tool through slits in the collet, even at high spindle speeds. Tool life and surface finish is improved as a result of efficient chip evacuation. Rubber seals are provided within the nut and body in order to prevent coolant leakage.

COOLANT PRESSURE
1,000 PSI



MEGA E COLLET

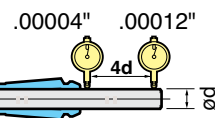

Collet Class	T.I.R.	
	At nose	At end of test bar
AA	Within .00004"	Within .00012"

High Clamping Force

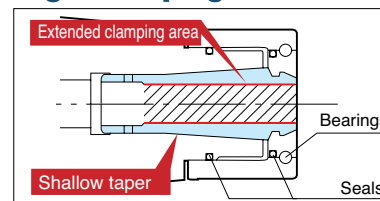

MEGA DOUBLE POWER CHUCK® PAT. PG. 23

Clamping Range: $\phi.625'' - \phi1.500''$



For end mills

MAX.
30,000 RPM
BCV= 30,000 RPM
BBT= 30,000 RPM

Coolant-through Nozzles

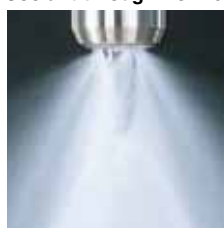

Complete fit of nut and body achieves high rigidity as an integral body.

In the case of a conventional milling chuck, the inner taper of the nut contacts only with the body when tightened. However, there is still a gap between the nut and body. The large fit diameter of the nut provides higher rigidity as if the chuck and nut were an integral body.



This superior rigidity assures heavy cutting without chatter.

Effective Coolant Supply

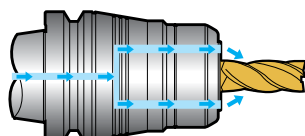

- For improved surface finish
- Extended tool life
- Smoother chip evacuation
- Cooling & lubricating of tools

BASIC ARBORS

PG. 26



End Mill Holder



Shell Mill Adapter



Shrink Fit Holder



Blank Bar

FULLCUT MILL

PG. 30

Indexable insert end mills with both excellent sharpness and toughness, achieving the performance of solid end mills

Strong cutting edge reduces edge chipping.

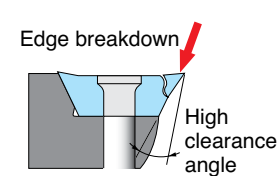

Other manufacturers

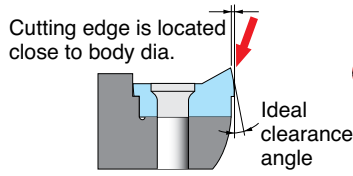

Fullcut Mill

Low cutting resistance

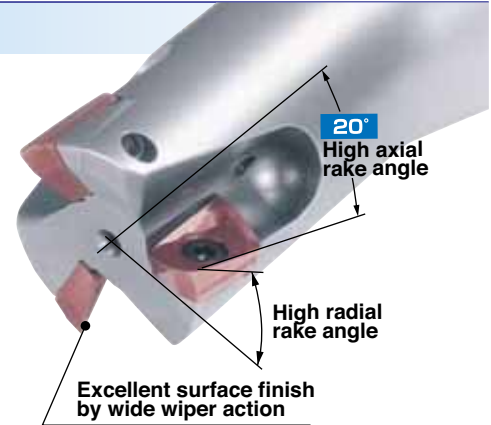

FULLCUT MILL FCR Type Ramping & Helical Milling Cutter PG. 30

Cutter Dia: ϕ .625" - ϕ .1250"

Unique inserts designed for ramping make multi-functional cutting possible.

Higher rigidity with integral body with dual contact system.



BIG-PLUS[®]
DUAL CONTACT
BCV Type



For multi-functional cutting

Shoulder milling

Ramping

Helical milling

Plunge milling

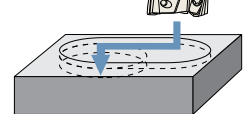
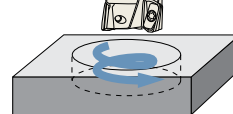
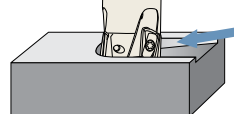
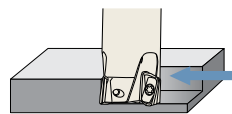

FULLCUT MILL FCM Type Square Shoulder & Slot Milling Cutter PG. 31

Cutter Dia: ϕ .625" - ϕ 2.000"

The indexable end mill that combines sharpness and rigidity and has no match.

A variety of shanks including simultaneous fit with integral body.



BIG-PLUS[®]
DUAL CONTACT
BCV Type



BIG-PLUS[®]
DUAL CONTACT
BBT Type



Evaluation of resistance to breakdown of cutting edge

Tough cutting edge of the Fullcut Mill is proven.

Evaluation of the total cutting length was performed by milling a most arduous workpiece comprised of continuous holes creating the situation most likely to cause edge chipping.

KAISER KAB BORING SYSTEM PG. 35

**From integral to a build-up modular system.
Accurate repeatability of $2\mu\text{m}$ or less**

Wide range of capacity $\varnothing.016'' - \varnothing46.46''$

Repeatability **Within .00008''**

BIG + KAISER

Basic holder for
KAB BORING SYSTEM

For Kaiser Boring System, please refer to catalog **No. 307A**

Large assortment of boring heads and inserts



ABS MODULAR SYSTEM PG. 36

Suitable for use with Komet ABS modular tooling system.



Basic Holder



BIG Komet ABS is produced under the license from Komet in Germany, and maintains interchangeability with their products.

BIG COROMANT CAPTO PG. 36

Suitable for use with Capto modular tooling system.



BIG Coromant Capto Basic Holder



BIG Coromant Capto is produced under the license from AB Sandvik Coromant in Sweden, and maintains interchangeability with their products.

BCV TURNING TOOLING SYSTEM PG. 37

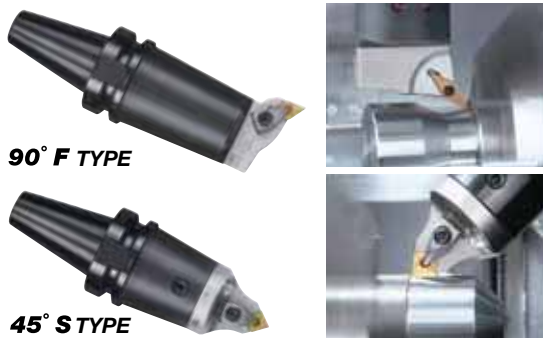

The very first modular tooling system for turning applications. Turning tools offer precise and reliable machining for Mill-Turn machines.

Wide variety of cartridges promotes setup time reduction and cost efficiency.



ACCESSORIES PG. 49

SPINDLE CLEANER

Keep the spindle of your machine absolutely clean.



α TOOLING CLEANER

Dirt and oil on the "taper" and "face" of CAT & BT taper holders can be easily cleaned off.

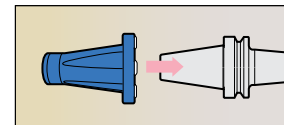

α TAPER CLEANER

For cleaning the internal collet taper.

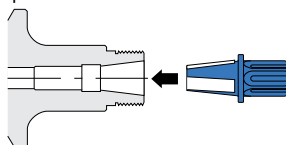

α WIPER CLEANER

For cleaning the clamping bore of shrink fit holders.

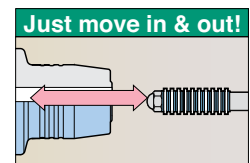

MEGA MICRO CHUCK®

Clamping Range: $\varnothing.018''$ - $\varnothing.238''$



A slim nut and taper design prevents interference in applications with micro drills and end mills.

**MAX
40,000
RPM**

- Model Description
- B** | **CV40** - **MEGA** | **3** | **S** - **2.5** | **T**
- Taper Type
- L= Projection Length (in)
- Micro Chuck
- Max. Capacity (mm)
- Mega Chuck Series
- CAT Shank No.
- BIG-PLUS® System

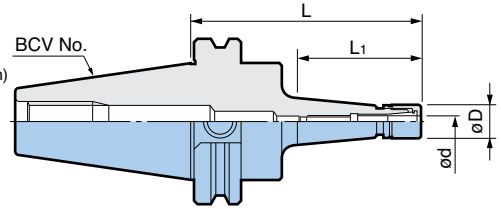

CAT SHANK **BCV40** ASME B5.50-1994

BIG-PLUS® tools can be used in machining centers with conventional spindles.

Model	$\varnothing d$	$\varnothing D$	L	L1	Collet	Nut	Wrench	Max. RPM	Weight (lbs)
BCV40-MEGA3S-2.5T -4T	.018 - .128	.394	2.50	1.01	NBC3S-□	MGN3S	MGR10	35,000	2.18
			4.00	2.38				25,000	2.36
-MEGA4S-2.5T -4T	.018 - .159	.472	2.50	1.01	NBC4S-□	MGN4S	MGR12	35,000	2.21
			4.00	2.38				25,000	2.38
-MEGA6S-2.5T -4T	.018 - .238	.551	2.50	1.01	NBC6S-□	MGN6S	MGR14	35,000	2.23
			4.00	2.38				25,000	2.43



- Model Description
- B** | **BT30** - **MEGA** | **3** | **S** - **45** | **T**
- Taper Type
- L= Projection Length (mm)
- Micro Chuck
- Max. Capacity (mm)
- Mega Chuck Series
- BT Shank No.
- BIG-PLUS® System

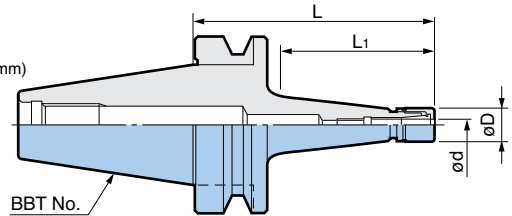

BT SHANK **BBT30/40** MAS403

BIG-PLUS® tools can be used in machining centers with conventional spindles.

Model	$\varnothing d$	$\varnothing D$	L	L1	Collet	Nut	Wrench	Max. RPM	Weight (lbs)
BBT30-MEGA3S-45T -75T -90T -105T	.018 - .128	.394	1.77	.79	NBC3S-□	MGN3S	MGR10	40,000	.84
			2.95	1.85				40,000	.93
			3.54	2.44				35,000	.99
			4.13	3.03				30,000	1.08
-MEGA4S-60T -75T -90T -105T -120T	.018 - .159	.472	2.36	1.26	NBC4S-□	MGN4S	MGR12	40,000	.88
			2.95	1.85				40,000	.95
			3.54	2.44				35,000	1.01
			4.13	3.03				30,000	1.10
-MEGA6S-60T -75T -90T -105T -120T	.018 - .238	.551	2.36	1.26	NBC6S-□	MGN6S	MGR14	40,000	.90
			2.95	1.85				40,000	.97
			3.54	2.44				35,000	1.04
			4.13	3.03				30,000	1.15
BBT40-MEGA3S-60T -90T -120T	.018 - .128	.394	2.36	1.06	NBC3S-□	MGN3S	MGR10	35,000	2.18
			3.54	2.24				28,000	2.29
			4.72	3.42				22,000	2.47
			2.36	1.06				35,000	2.21
-MEGA4S-60T -75T -90T -105T -120T -135T	.018 - .159	.472	2.95	1.65	NBC4S-□	MGN4S	MGR12	32,000	2.25
			3.54	2.24				28,000	2.32
			4.13	2.83				25,000	2.38
			4.72	3.42				22,000	2.49
-MEGA6S-60T -75T -90T -105T -120T -135T	.018 - .238	.551	2.36	1.06	NBC6S-□	MGN6S	MGR14	35,000	2.23
			2.95	1.65				32,000	2.27
			3.54	2.24				28,000	2.34
			4.13	2.83				25,000	2.43
			4.72	3.42				22,000	2.54
			5.31	4.01				20,000	2.69

1. Mega Nut is included. Collet and wrench must be ordered separately.
2. Weight does not include collet.

3. The "max" allowable spindle speed listed in the table is directly influenced by the rigidity of the machine and balance of the cutting tool. Therefore, the "max" allowable speed may not always be achievable.

MEGA MICRO COLLET

ULTRA SMALL HIGH PRECISION COLLET

Interval of clamping dia. is .004". Taper and straight design achieves .00004" T.I.R. at the collet nose.

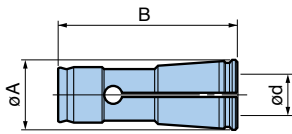

- Model Description: **NBC 3 S - 0.5 AA**
- NBC: New Baby Collet
- 3: Body Size
- S: Micro Chuck
- 0.5: Max. Capacity (mm)
- AA: Collet Class

MEGA3S	
Model	Clamping Range ød
NBC3S-0.5AA	.018 - .022
-0.6AA	.022 - .026
-0.7AA	.026 - .030
-0.8AA	.030 - .033
-0.9AA	.033 - .037
-1.0AA	.037 - .041
-1.1AA	.041 - .045
-1.2AA	.045 - .049
-1.3AA	.049 - .053
-1.4AA	.053 - .057
-1.5AA	.057 - .061
-1.6AA	.061 - .065
-1.7AA	.065 - .069
-1.8AA	.069 - .073
-1.9AA	.073 - .077
-2.0AA	.077 - .081
-2.1AA	.081 - .085
-2.2AA	.085 - .089
-2.3AA	.089 - .093
-2.4AA	.093 - .096
-2.5AA	.096 - .100
-2.6AA	.100 - .104
-2.7AA	.104 - .108
-2.8AA	.108 - .112
-2.9AA	.112 - .116
-3.0AA	.116 - .120
-3.1AA	.120 - .124
-3.175AA	.123 - .127
-3.2AA	.124 - .128

øA= .239 B= .740

MEGA4S	
Model	Clamping Range ød
NBC4S-0.5AA	.018 - .022
-0.6AA	.022 - .026
-0.7AA	.026 - .030
-0.8AA	.030 - .033
-0.9AA	.033 - .037
-1.0AA	.037 - .041
-1.1AA	.041 - .045
-1.2AA	.045 - .049
-1.3AA	.049 - .053
-1.4AA	.053 - .057
-1.5AA	.057 - .061
-1.6AA	.061 - .065
-1.7AA	.065 - .069
-1.8AA	.069 - .073
-1.9AA	.073 - .077
-2.0AA	.077 - .081
-2.1AA	.081 - .085
-2.2AA	.085 - .089
-2.3AA	.089 - .093
-2.4AA	.093 - .096
-2.5AA	.096 - .100
-2.6AA	.100 - .104
-2.7AA	.104 - .108
-2.8AA	.108 - .112
-2.9AA	.112 - .116
-3.0AA	.116 - .120
-3.1AA	.120 - .124
-3.175AA	.123 - .127
-3.2AA	.124 - .128
-3.3AA	.128 - .132
-3.4AA	.132 - .136
-3.5AA	.136 - .140
-3.6AA	.140 - .144
-3.7AA	.144 - .148
-3.8AA	.148 - .152
-3.9AA	.152 - .156
-4.0AA	.156 - .159

øA= .291 B= .886

MEGA6S			
Model	Clamping Range ød	Model	Clamping Range ød
NBC6S-0.5AA	.018 - .022	NBC6S-4.1AA	.159 - .163
-0.6AA	.022 - .026	-4.2AA	.163 - .167
-0.7AA	.026 - .030	-4.3AA	.167 - .171
-0.8AA	.030 - .033	-4.4AA	.171 - .175
-0.9AA	.033 - .037	-4.5AA	.175 - .179
-1.0AA	.037 - .041	-4.6AA	.179 - .183
-1.1AA	.041 - .045	-4.7AA	.183 - .187
-1.2AA	.045 - .049	-4.7625AA	.186 - .189
-1.3AA	.049 - .053	-4.8AA	.187 - .191
-1.4AA	.053 - .057	-4.9AA	.191 - .195
-1.5AA	.057 - .061	-5.0AA	.195 - .199
-1.6AA	.061 - .065	-5.1AA	.199 - .203
-1.7AA	.065 - .069	-5.2AA	.203 - .207
-1.8AA	.069 - .073	-5.3AA	.207 - .211
-1.9AA	.073 - .077	-5.4AA	.211 - .215
-2.0AA	.077 - .081	-5.5AA	.215 - .219
-2.1AA	.081 - .085	-5.6AA	.219 - .222
-2.2AA	.085 - .089	-5.7AA	.222 - .226
-2.3AA	.089 - .093	-5.8AA	.226 - .230
-2.4AA	.093 - .096	-5.9AA	.230 - .234
-2.5AA	.096 - .100	-6.0AA	.234 - .238
-2.6AA	.100 - .104		
-2.7AA	.104 - .108		
-2.8AA	.108 - .112		
-2.9AA	.112 - .116		
-3.0AA	.116 - .120		
-3.1AA	.120 - .124		
-3.175AA	.123 - .127		
-3.2AA	.124 - .128		
-3.3AA	.128 - .132		
-3.4AA	.132 - .136		
-3.5AA	.136 - .140		
-3.6AA	.140 - .144		
-3.7AA	.144 - .148		
-3.8AA	.148 - .152		
-3.9AA	.152 - .156		
-4.0AA	.156 - .159		

øA= .370 B= .965

Collet Class	T.I.R.	
	At nose	At end of test bar
AA	Within .00004"	Within .00012"

Clamping Range: ø.018" - ø.238"

STRAIGHT SHANK TYPE



- Model Description: **ST.375 - MEGA 3 S - 120**
- ST.375: Cylindrical Shank Size (in)
- MEGA: Mega Chuck Series
- 3: Body Size
- S: Micro Chuck
- 120: L= Length (mm)

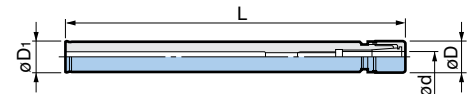

Model	ød	øD	øD1	L	Collet	Nut	Wrench	Weight (lbs)
ST.375-MEGA3S-120	.018 - .128	.394	.375	4.724	NBC3S-□	MGN3S	MGR10	.06
ST.500-MEGA4S-130	.018 - .159	.472	.500	5.118	NBC4S-□	MGN4S	MGR12	.12
-160				6.299				.15
ST.625-MEGA6S-160	.018 - .238	.551	.625	6.299	NBC6S-□	MGN6S	MGR14	.23
-200				7.874				.27

Accessories (Need to be ordered separately)			Spare Parts	
	Mega Wrench	Collet	Mega Nut	
Mega Micro Chuck	Model	Model	Model	
MEGA3S	MGR10	NBC3S-□	MGN3S	
MEGA4S	MGR12	NBC4S-□	MGN4S	
MEGA6S	MGR14	NBC6S-□	MGN6S	

MEGA NEW BABY CHUCK[®] Coolant-Through Hole

Clamping Range: $\varnothing.010''$ - $\varnothing.787''$

The chuck designed for high speed cutting utilizes ultra precise New Baby Collets that guarantee .00004" T.I.R. at the collet nose.

**MAX
40,000
RPM**



- Model Description
- B** CV40 - **MEGA** **6** **N** - **2.5**
- L= Projection Length (in)
- New Baby Chuck
- Max. Capacity (mm)
- Mega Chuck Series
- CV Shank No.
- BIG-PLUS[®] System

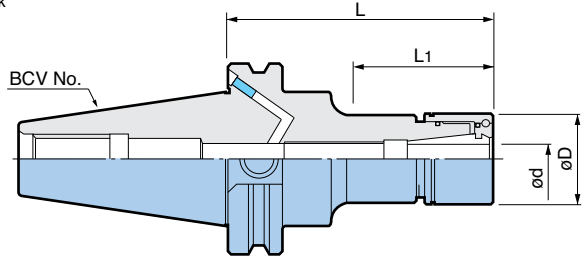

※Coolant bores in accordance to DIN69871/Form B

CAT SHANK BCV40

ASME B5.50-1994

BIG-PLUS[®] tools can be used in machining centers with conventional spindles.

Model	$\varnothing d$	$\varnothing D$	L	L1	Collet	Nut	Wrench	Max. RPM	Weight (lbs)
BCV40-MEGA6N-2.5	.010 - .236	.787	2.50	1.04	NBC6-□	MGN6	MGR20	35,000	2.32
-4			4.00	2.22				30,000	2.54
-5			5.00	3.22				20,000	2.65
-6			6.00	4.22				15,000	2.76
-MEGA8N-2.5	.020 - .315	.984	2.50	1.04	NBC8-□	MGN8	MGR25	35,000	2.43
-4			4.00	2.30				30,000	2.65
-5			5.00	3.30				20,000	2.87
-6			6.00	4.30				15,000	3.09
-MEGA10N-2.5	.059 - .394	1.181	2.50	1.05	NBC10-□	MGN10	MGR30	35,000	2.54
-4			4.00	2.38				25,000	2.98
-5			5.00	3.38				20,000	3.20
-6			6.00	4.38				15,000	3.53
-MEGA13N-2.5	.098 - .512	1.387	2.50	1.17	NBC13-□	MGN13	MGR35	30,000	2.65
-4			4.00	2.46				25,000	3.20
-5			5.00	3.46				20,000	3.53
-6			6.00	4.46				15,000	3.97
-MEGA16N-2.5	.098 - .630	1.654	2.50	1.18	NBC16-□	MGN16	MGR42	30,000	2.87
-4			4.00	2.62				20,000	3.64
-5			5.00	3.62				15,000	4.19
-6			6.00	4.62				12,000	4.74
-MEGA20N-2.5	.098 - .787	1.811	2.50	1.75	NBC20-□	MGN20	MGR46	30,000	2.98
-4			4.00	3.25				20,000	3.97
-5			5.00	4.25				15,000	4.63
-6			6.00	5.25				12,000	5.29

1. Mega New Baby Nut is included. Collet and wrench must be ordered separately.
 2. Weight does not include collet.
 3. Designed to be capable of supplying coolant through spindle and flange.
 4. The "max" allowable spindle speed listed in the table is directly influenced by the rigidity of the machine and balance of the cutting tool. Therefore, the "max" allowable speed may not always be achievable.
- ※ Bores on Form B are sealed with set screws on delivery.

For NEW BABY COLLET PG. 17

For MEGA NUT PG. 18

For END MILL COLLET PG. 18

For MEGA PERFECT SEAL PG. 19

For MEGA WRENCH PG. 18

CAT SHANK BCV50 ASME B5.50-1994

BIG-PLUS® tools can be used in machining centers with conventional spindles.

Model	ød	øD	L	L1	Collet	Nut	Wrench	Max. RPM	Weight (lbs)
BCV50-MEGA6N-3.5	.010 - .236	.787	3.50	1.72	NBC6-□	MGN6	MGR20	20,000	6.95
-5			5.00	3.03				20,000	7.06
-6			6.00	4.03				15,000	7.28
-MEGA8N-3.5	.020 - .315	.984	3.50	1.72	NBC8-□	MGN8	MGR25	20,000	7.06
-5			5.00	3.03				20,000	7.39
-6			6.00	4.03				15,000	7.61
-MEGA10N-3.5	.059 - .394	1.181	3.50	1.72	NBC10-□	MGN10	MGR30	20,000	7.28
-5			5.00	3.03				20,000	7.72
-6			6.00	4.03				15,000	7.94
-8			8.00	6.03				12,000	8.60
-MEGA13N-3.5	.098 - .512	1.378	3.50	1.72	NBC13-□	MGN13	MGR35	18,000	7.50
-5			5.00	3.22				18,000	8.05
-6			6.00	4.03				16,000	8.49
-8			8.00	6.03				12,000	9.26
-MEGA16N-3.5	.098 - .630	1.654	3.50	1.72	NBC16-□	MGN16	MGR42	17,000	7.83
-5			5.00	3.22				17,000	8.71
-6			6.00	4.22				16,000	9.26
-8			8.00	6.22				13,000	10.36
-MEGA20N-3.5	.098 - .787	1.811	3.50	1.80	NBC20-□	MGN20	MGR46	16,000	8.05
-5			5.00	3.22				16,000	9.04
-6			6.00	4.22				15,000	9.70
-8			8.00	6.22				13,000	11.03

1. Mega New Baby Nut is included. Collet and wrench must be ordered separately.
 2. Weight does not include collet.
 3. Designed to be capable of supplying coolant through spindle or flange.
 4. The "max" allowable spindle speed listed in the table is directly influenced by the rigidity of the machine and balance of the cutting tool. Therefore, the "max" allowable speed may not always be achievable.
- ※ Bore on Form B are sealed with set screws on delivery.

☞ For NEW BABY COLLET PG. 17

☞ For MEGA NUT PG. 18

☞ For END MILL COLLET PG. 18

☞ For MEGA PERFECT SEAL PG. 19

☞ For MEGA WRENCH PG. 18

● Plug Screw for flange through coolant

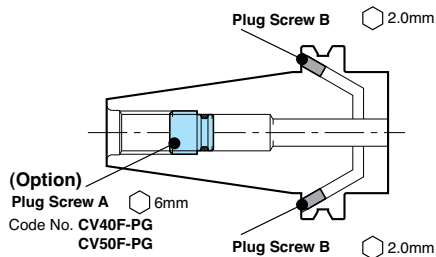

Plug Screw A (option) prevents coolant leakage through retention knobs.

Bore on Form B are sealed with Plug Screw B.

*Remove 2 pcs. Plug Screw B from end face of flange.

*Failure to use the Plug Screw A or other sealing method may result in coolant contamination of the spindle and lead to premature failure or accidents.

MEGA NEW BABY CHUCK[®] Coolant-Through Hole

Clamping Range: $\varnothing.010''$ - $\varnothing.787''$



• Model Description

B **BT30** - **MEGA** **6** **N** - **60**

- L= Projection Length (mm)
- New Baby Chuck
- Max. Capacity (mm)
- Mega Chuck Series
- BT Shank No.
- BIG-PLUS[®] System

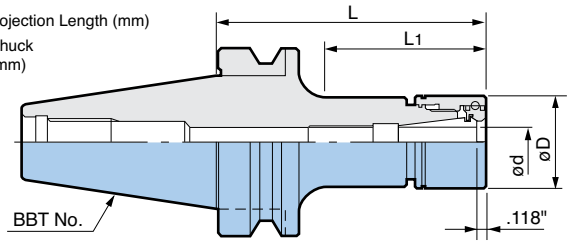

BT SHANK BBT30/40 MAS403

BIG-PLUS[®] tools can be used in machining centers with conventional spindles.

Model	$\varnothing d$	$\varnothing D$	L	L1	Collet	Nut	Wrench	Max. RPM	Weight (lbs)
BBT30-MEGA6N-60	.010 - .236	.787	2.36	1.26	NBC6-□	MGN6	MGR20	40,000	1.04
-75			2.95	1.85				35,000	1.10
-90			3.54	2.44				30,000	1.17
-105			4.13	3.03				20,000	1.23
-120			4.72	3.62				18,000	1.30
-MEGA8N-60	.020 - .315	.984	2.36	1.34	NBC8-□	MGN8	MGR25	40,000	1.12
-75			2.95	1.93				35,000	1.23
-90			3.54	2.52				30,000	1.35
-105			4.13	3.11				20,000	1.48
-120			4.72	3.70				18,000	1.59
-MEGA10N-60	.059 - .394	1.181	2.36	1.34	NBC10-□	MGN10	MGR30	40,000	1.19
-75			2.95	1.93				30,000	1.35
-90			3.54	2.52				25,000	1.50
-105			4.13	3.11				18,000	1.65
-120			4.72	3.70				15,000	1.81
-MEGA13N-60	.098 - .512	1.378	2.36	1.34	NBC13-□	MGN13	MGR35	40,000	1.19
-75			2.95	1.93				30,000	1.39
-90			3.54	2.52				25,000	1.59
-105			4.13	3.11				18,000	1.81
-120			4.72	3.70				15,000	2.01
-MEGA16N-60	.098 - .630	1.654	2.36	1.42	NBC16-□	MGN16	MGR42	35,000	1.46
-75			2.95	2.01				25,000	1.79
-90			3.54	2.60				20,000	2.09
-105			4.13	3.19				18,000	2.43
-120			4.72	3.70				15,000	2.81
-MEGA20N-60	.098 - .787	1.811	2.36	—	NBC20-□	MGN20	MGR46	30,000	1.57
-75			2.95	—				20,000	1.90
-90			3.54	—				15,000	2.21
-105			4.13	—				13,000	2.54
-120			4.72	—				10,000	2.91
BBT40-MEGA6N-60	.010 - .236	.787	2.36	0.91	NBC6-□	MGN6	MGR20	35,000	2.21
-75			2.95	1.50				35,000	2.32
-90			3.54	2.09				35,000	2.43
-105			4.13	2.68				20,000	2.51
-120			4.72	3.27				20,000	2.60
-135			5.31	3.86				20,000	2.65
-165			6.50	5.04				14,000	2.65
-200			7.87	6.42				9,000	2.87
-MEGA8N-60	.020 - .315	.984	2.36	1.06	NBC8-□	MGN8	MGR25	35,000	2.21
-75			2.95	1.65				35,000	2.32
-90			3.54	2.24				35,000	2.43
-105			4.13	2.83				20,000	2.51
-120			4.72	3.43				20,000	2.60
-135			5.31	4.02				20,000	2.87
-165			6.50	5.20				14,000	2.87
-200			7.87	6.57				9,000	3.09

1. Mega New Baby Nut is included. Collet and wrench must be ordered separately.
2. Weight does not include collet.
3. Designed to be capable of supplying coolant through spindle.
4. The "max" allowable spindle speed listed in the table is directly influenced by the rigidity of the machine and balance of the cutting tool. Therefore, the "max" allowable speed may not always be achievable.

MEGA NEW BABY CHUCK®

NEW BABY COLLET



The New Baby Collet is world renowned for its unmatched accuracy and precision. It offers runout accuracy of .00004" T.I.R. at the collet nose.

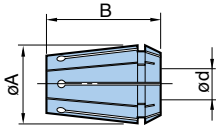

Model Description

- NBC 6 -0.5 AA**
- Collet Class
 - Max. Capacity (mm)
 - Body Size
 - New Baby Collet

Collet Class	T.I.R.	
	At nose	At end of test bar
AA	Within .00004"	Within .00012"

.00004" .00012"	

- Collapsibility is .010" for NBC6 and .020" for NBC8 - NBC20.
- For best performance, cutting tool shanks should be cylindrical without flats and be as long as the clamping section of the collet bore.

MEGA6N	
Model	Clamping Range ød
NBC6-0.5AA	.010 - .020
-0.75AA	.020 - .030
-1AA	.030 - .039
-1.25AA	.039 - .049
-1.5AA	.049 - .059
-1.75AA	.059 - .069
-2AA	.069 - .079
-2.25AA	.079 - .089
-2.5AA	.089 - .098
-2.75AA	.098 - .108
-3AA	.108 - .118
-3.175AA	.115 - .125
-3.25AA	.118 - .128
-3.5AA	.128 - .138
-3.75AA	.138 - .148
-4AA	.148 - .157
-4.25AA	.157 - .167
-4.5AA	.167 - .177
-4.75AA	.177 - .187
-5AA	.187 - .197
-5.25AA	.197 - .207
-5.5AA	.207 - .217
-5.75AA	.217 - .226
-6AA	.226 - .236

øA= .374 B= .551

MEGA13N	
Model	Clamping Range ød
NBC13-3AA	.098 - .118
-3.175AA	.115 - .125
-3.5AA	.118 - .138
-4AA	.138 - .157
-4.5AA	.157 - .177
-5AA	.177 - .197
-5.5AA	.197 - .217
-6AA	.217 - .236
-6.5AA	.236 - .256
-7AA	.256 - .276
-7.5AA	.276 - .295
-8AA	.295 - .315
-8.5AA	.315 - .335
-9AA	.335 - .354
-9.5AA	.354 - .375
-10AA	.376 - .394
-10.5AA	.394 - .413
-11AA	.413 - .433
-11.5AA	.433 - .453
-12AA	.453 - .472
-12.5AA	.472 - .492
-13AA	.492 - .512

øA= .807 B= 1.220

MEGA8N	
Model	Clamping Range ød
NBC8-0.75AA	.020 - .030
-1AA	.030 - .039
-1.25AA	.039 - .049
-1.5AA	.049 - .059
-1.75AA	.059 - .069
-2AA	.069 - .079
-2.25AA	.079 - .089
-2.5AA	.089 - .098
-2.75AA	.098 - .108
-3AA	.108 - .118
-3.175AA	.115 - .125
-3.5AA	.118 - .138
-4AA	.138 - .157
-4.5AA	.157 - .177
-5AA	.177 - .197
-5.5AA	.197 - .217
-6AA	.217 - .236
-6.5AA	.236 - .256
-7AA	.256 - .276
-7.5AA	.276 - .295
-8AA	.295 - .315

øA= .492 B= .709

MEGA16N	
Model	Clamping Range ød
NBC16-3AA	.098 - .118
-3.5AA	.118 - .138
-4AA	.138 - .157
-4.5AA	.157 - .177
-5AA	.177 - .197
-5.5AA	.197 - .217
-6AA	.217 - .236
-6.5AA	.236 - .256
-7AA	.256 - .276
-7.5AA	.276 - .295
-8AA	.295 - .315
-8.5AA	.315 - .335
-9AA	.335 - .354
-9.5AA	.354 - .375
-10AA	.376 - .394
-10.5AA	.394 - .413
-11AA	.413 - .433
-11.5AA	.433 - .453
-12AA	.453 - .472
-12.5AA	.472 - .492
-13AA	.492 - .512
-13.5AA	.512 - .531
-14AA	.531 - .551
-14.5AA	.551 - .571
-15AA	.571 - .591
-15.5AA	.591 - .610
-16AA	.610 - .630

øA= 1.004 B= 1.378

MEGA10N	
Model	Clamping Range ød
NBC10-1.75AA	.059 - .069
-2AA	.069 - .079
-2.25AA	.079 - .089
-2.5AA	.089 - .098
-2.75AA	.098 - .108
-3AA	.108 - .118
-3.175AA	.115 - .125
-3.5AA	.118 - .138
-4AA	.138 - .157
-4.5AA	.157 - .177
-5AA	.177 - .197
-5.5AA	.197 - .217
-6AA	.217 - .236
-6.5AA	.236 - .256
-7AA	.256 - .276
-7.5AA	.276 - .295
-8AA	.295 - .315
-8.5AA	.315 - .335
-9AA	.335 - .354
-9.5AA	.354 - .375
-10AA	.376 - .394

øA= .650 B= 1.063

MEGA20N	
Model	Clamping Range ød
NBC20-3AA	.098 - .118
-3.5AA	.118 - .138
-4AA	.138 - .157
-4.5AA	.157 - .177
-5AA	.177 - .197
-5.5AA	.197 - .217
-6AA	.217 - .236
-6.5AA	.236 - .256
-7AA	.256 - .276
-7.5AA	.276 - .295
-8AA	.295 - .315
-8.5AA	.315 - .335
-9AA	.335 - .354
-9.5AA	.354 - .375
-10AA	.376 - .394
-10.5AA	.394 - .413
-11AA	.413 - .433
-11.5AA	.433 - .453
-12AA	.453 - .472
-12.5AA	.472 - .492
-13AA	.492 - .512
-13.5AA	.512 - .531
-14AA	.531 - .551
-14.5AA	.551 - .571
-15AA	.571 - .591
-15.5AA	.591 - .610
-16AA	.610 - .630
-16.5AA	.630 - .650
-17AA	.650 - .669
-17.5AA	.669 - .689
-18AA	.689 - .709
-18.5AA	.709 - .728
-19AA	.728 - .750
-19.5AA	.751 - .768
-20AA	.768 - .787

øA= 1.122 B= 1.496

NEW BABY COLLET



For END MILL

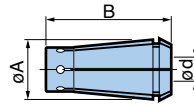

• Model Description
NBC 6 - 1/8 E AA
 • Collet Class
 • End Mill Type
 • Clamping Size (in)
 • Body Size
 • New Baby Collet

Note: This collet is not compatible with Profit Maker Tools.

The tolerance of the cutting tool shank must be within h7.

MEGA6N		
	Clamping Size ød	Model
INCH SIZE	.125	NBC6-1/8EAA
	.187	-3/16EAA
METRIC SIZE	3.0	NBC6-3EAA
	4.0	-4EAA
	5.0	-5EAA
	6.0	-6EAA

øA= .362 B= .669

MEGA13N		
	Clamping Size ød	Model
INCH SIZE	.125	NBC13-1/8EAA
	.187	-3/16EAA
	.250	-1/4EAA
	.375	-3/8EAA
	.500	-1/2EAA
METRIC SIZE	3.0	NBC13-3EAA
	4.0	-4EAA
	5.0	-5EAA
	6.0	-6EAA
	8.0	-8EAA
	10.0	-10EAA
	12.0	-12EAA

øA= .787 B= 1.496

MEGA8N		
	Clamping Size ød	Model
INCH SIZE	.125	NBC8-1/8EAA
	.187	-3/16EAA
	.250	-1/4EAA
METRIC SIZE	3.0	NBC8-3EAA
	4.0	-4EAA
	5.0	-5EAA
	6.0	-6EAA
	8.0	-8EAA

øA= .472 B= .787

MEGA16N		
	Clamping Size ød	Model
INCH SIZE	.125	NBC16-1/8EAA
	.187	-3/16EAA
	.250	-1/4EAA
	.375	-3/8EAA
	.500	-1/2EAA
	.625	-5/8EAA
METRIC SIZE	3.0	NBC16-3EAA
	4.0	-4EAA
	5.0	-5EAA
	6.0	-6EAA
	8.0	-8EAA
	10.0	-10EAA
	12.0	-12EAA
	16.0	-16EAA

øA= .984 B= 1.654

MEGA10N		
	Clamping Size ød	Model
INCH SIZE	.125	NBC10-1/8EAA
	.187	-3/16EAA
	.250	-1/4EAA
	.375	-3/8EAA
METRIC SIZE	3.0	NBC10-3EAA
	4.0	-4EAA
	5.0	-5EAA
	6.0	-6EAA
	8.0	-8EAA
	10.0	-10EAA

øA= .630 B= 1.260

MEGA20N		
	Clamping Size ød	Model
INCH SIZE	.125	NBC20-1/8EAA
	.187	-3/16EAA
	.250	-1/4EAA
	.375	-3/8EAA
	.500	-1/2EAA
	.625	-5/8EAA
METRIC SIZE	.750	-3/4EAA
	3.0	NBC20-3EAA
	4.0	-4EAA
	5.0	-5EAA
	6.0	-6EAA
	8.0	-8EAA
	10.0	-10EAA
	12.0	-12EAA
	14.0	-14EAA
	16.0	-16EAA
20.0	-20EAA	

øA= 1.102 B= 1.772

COLLET EJECTOR



Collet Ejector can easily and quickly remove small sizes of New Baby Collets from Mega Nuts.



NEW BABY		
Model	Nut	Collet
NBC6-CE	MGN6	NBC6
NBC8-CE	MGN8	NBC8
NBC10-CE	MGN10	NBC10
NBC13-CE	MGN13	NBC13

NEW BABY END MILL		
Model	Nut	Collet
NBC6E-CE	MGN6	NBC6-E
NBC8E-CE	MGN8	NBC8-E
NBC10E-CE	MGN10	NBC10-E
NBC13E-CE	MGN13	NBC13-E

MEGA NEW BABY CHUCK®

MEGA PERFECT SEAL PAT. US Patent No. 5975817



MAX. COOLANT PRESSURE
1,000 PSI

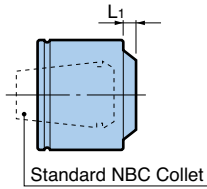
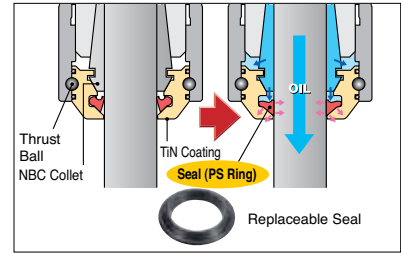

- Model Description
MPS 6 - 03035
- Tool Shank Dia. Clamping Range: ϕ .118 - ϕ .138
- Body Size
- Mega Perfect Seal

2-Way Coolant

Through Tools

Jet Through



With PS Ring

Without PS Ring

Reliable coolant supply to the tool tip!

Unique design increases sealing performance with higher coolant pressure to create a "perfect seal".

Model	Cutter Shank Dia.	L1	Collet Model	Model	Cutter Shank Dia.	L1	Collet Model		
MPS6-03035	.118 - .138	.091	NBC6-3-3.75	MPS16-03035	.118 - .138	.157	NBC16-3-4		
-0304	.118 - .157		-3-4.25	-0304	.118 - .157		-3-4.5		
-04045	.157 - .177		-4-4.75	-04045	.157 - .177		-4-5		
-0405	.157 - .197		-4-5.25	-0405	.157 - .197		-4-5.5		
-05055	.197 - .217		-5-5.75	-05055	.197 - .217		-5-6		
-0506	.197 - .236		-5-6	-0506	.197 - .236		-5-6.5		
MPS8-03035	.118 - .138	.154	NBC8-3-4	MPS8-06065	.236 - .256	.169	-6-7		
-0304	.118 - .157		-3-4.5	-0607	.236 - .276		-6-7.5		
-04045	.157 - .177		-4-5	-07075	.276 - .295		-7-8		
-0405	.157 - .197		-4-5.5	-0708	.276 - .315		-7-8.5		
-05055	.197 - .217		-5-6	-08085	.315 - .335		-8-9		
-0506	.197 - .236		-5-6.5	-0809	.315 - .354		-8-9.5		
-06065	.236 - .256	.134	-6-7	-09095	.354 - .375	.181	-9-10		
-0607	.236 - .276		-6-7.5	-0910	.354 - .394		-9-10.5		
-07075	.276 - .295		-7-8	-10105	.394 - .413		-10-11		
-0708	.276 - .315		-7-8	-1011	.394 - .433		-10-11.5		
MPS10-03035	.118 - .138		.154	NBC10-3-4	-11115		.433 - .453	.201	-11-12
-0304	.118 - .157			-3-4.5	-1112		.433 - .472		-11-12.5
-04045	.157 - .177	-4-5		-12125	.472 - .492	-12-13			
-0405	.157 - .197	-4-5.5		-1213	.472 - .512	-12-13.5			
-05055	.197 - .217	-5-6		-1314	.512 - .551	-13-14.5			
-0506	.197 - .236	-5-6.5		-1415	.551 - .591	-14-15.5			
-06065	.236 - .256	.169	-6-7	-1516	.591 - .630	-15-16			
-0607	.236 - .276		-6-7.5	MPS20-03035	.118 - .138	.157	NBC20-3-4		
-07075	.276 - .295		-7-8	-0304	.118 - .157		-3-4.5		
-0708	.276 - .315		-7-8.5	-04045	.157 - .177		-4-5		
-08085	.315 - .335		-8-9	-0405	.157 - .197		-4-5.5		
-0809	.315 - .354		-8-9.5	-05055	.197 - .217		-5-6		
-09095	.354 - .375	-9-10	-0506	.197 - .236	-5-6.5				
-0910	.354 - .394	-9-10	-06065	.236 - .256	-6-7				
MPS13-03035	.118 - .138	.169	NBC13-3-4	-0607	.236 - .276	.169	-6-7.5		
-0304	.118 - .157		-3-4.5	-07075	.276 - .295		-7-8		
-04045	.157 - .177		-4-5	-0708	.276 - .315		-7-8.5		
-0405	.157 - .197		-4-5.5	-08085	.315 - .335		-8-9		
-05055	.197 - .217		-5-6	-0809	.315 - .354		-8-9.5		
-0506	.197 - .236		-5-6.5	-09095	.354 - .375		-9-10		
-06065	.236 - .256	.181	-6-7	-0910	.354 - .394	.181	-9-10.5		
-0607	.236 - .276		-6-7.5	-10105	.394 - .413		-10-11		
-07075	.276 - .295		-7-8	-1011	.394 - .433		-10-11.5		
-0708	.276 - .315		-7-8.5	-11115	.433 - .453		-11-12		
-08085	.315 - .335		-8-9	-1112	.433 - .472		-11-12.5		
-0809	.315 - .354		-8-9.5	-12125	.472 - .492		-12-13		
-09095	.354 - .375	.193	-9-10	-1213	.472 - .512	.181	-12-13.5		
-0910	.354 - .394		-9-10.5	-1314	.512 - .551		-13-14.5		
-10105	.394 - .413		-10-11	-1415	.551 - .591		-14-15.5		
-1011	.394 - .433		-10-11.5	-1516	.591 - .630		-15-16.5		
-11115	.433 - .453		-11-12	-1617	.630 - .669		-16-17.5		
-1112	.433 - .472		-11-12.5	-1718	.669 - .709		-17-18.5		
-12125	.472 - .492	.165	-12-13	-1819	.709 - .750	.181	-18-19.5		
-1213	.472 - .512		-12-13	-1920	.751 - .787		-19-20		

1. 1 pc. of PS Ring is included.
2. To supply coolant to the periphery of the cutting tool, Adjusting Screw should not be mounted.

PS RING

Replaceable seal used in Mega Perfect Seal

(Spare seal is recommended when coolant leaks due to damage of PS Ring.)



1 package contains
5 pcs. (1 size)

Model	MPS Model	Model	MPS Model	Model	MPS Model
PS-0304	MPS□-03035, 0304	PS-0809	MPS□-08085, 0809	PS-1314	MPS□-1314
0405	04045, 0405	0910	09095, 0910	1415	1415
0506	05055, 0506	1011	10105, 1011	1516	1516
0607	06065, 0607	1112	11115, 1112	1617	1617
0708	07075, 0708	1213	12125, 1213	1718	1718
				1819	1819
				1920	1920

MEGA E CHUCK®

Coolant-Through Hole

Clamping Range: ϕ .125" - ϕ .500" (ϕ 3mm - ϕ 12mm)

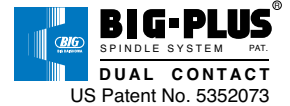

The Mega E Chuck utilizes the advanced technology of New Baby Collet Chucks for powerful and precise high speed end milling.

**MAX
40,000
RPM**



• Model Description

- B** | **CV40** - **MEGA** | **6** | **E** - **3**
- L= Projection Length (in)
 - Mega E Chuck
 - Max. Capacity (mm)
 - Mega Chuck Series
 - CAT Shank No.
 - BIG-PLUS® System

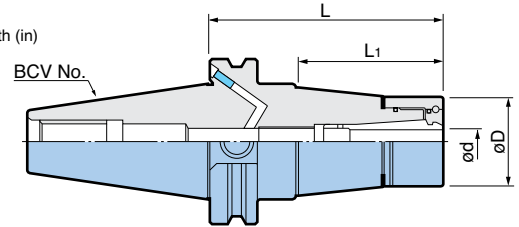

※Coolant bores in accordance to DIN69871/Form B

Plug Screw for flange through coolant

For details of plug screws, please refer to [PG. 14](#)

CAT SHANK BCV40/50 ASME B5.50-1994

BIG-PLUS® tools can be used in machining centers with conventional spindles.

Model	ϕ d	ϕ D	L	L1	Collet Model	Nut	Wrench	Max. RPM	Weight (lbs)					
BCV40-MEGA6E-3	.125 - .250 (3mm - 6mm)	.984	3.00	1.50	MEC6-□	MEN6	MGR25	35,000	2.54					
-4			4.00	2.42				29,000	2.98					
-5			5.00	3.54				29,000	3.42					
-6			6.00	4.54				20,000	3.75					
-MEGA8E-3	.125 - .250 (3mm - 8mm)	1.181	3.00	1.50	MEC8-□	MEN8	MGR30	30,000	2.76					
-4			4.00	2.54				29,000	3.20					
-5			5.00	3.58				29,000	3.64					
-6			6.00	4.58				20,000	4.30					
-MEGA10E-3	.125 - .375 (3mm - 10mm)	1.378	3.00	1.54	MEC10-□	MEN10	MGR35	30,000	2.87					
-4			4.00	2.58				29,000	3.42					
-5			5.00	3.58				29,000	3.86					
-6			6.00	4.58				22,000	4.52					
-MEGA13E-3	.125 - .500 (3mm - 12mm)	1.654	3.00	1.62	MEC13-□	MEN13	MGR42	30,000	3.20					
-4			4.00	2.62				29,000	3.75					
-5			5.00	3.62				29,000	4.30					
-6			6.00	4.62				22,000	4.85					
-MEGA13E-4	.125 - .500 (3mm - 12mm)	1.654	8.00	6.62	MEC13-□	MEN13	MGR42	16,000	6.06					
BCV50-MEGA6E-4			.125 - .250 (3mm - 6mm)	.984				4.00	2.42	MEC6-□	MEN6	MGR25	20,000	7.39
-5								5.00	3.42				20,000	7.83
-6								6.00	4.42				14,000	8.38
-MEGA8E-4	.125 - .250 (3mm - 8mm)	1.181	4.00	2.22	MEC8-□	MEN8	MGR30	20,000	7.72					
-5			5.00	3.22				20,000	8.27					
-6			6.00	4.22				16,000	9.04					
-MEGA10E-4	.125 - .375 (3mm - 10mm)	1.378	4.00	2.22	MEC10-□	MEN10	MGR35	20,000	8.05					
-5			5.00	3.22				20,000	8.60					
-6			6.00	4.22				16,000	9.59					
-MEGA13E-4	.125 - .500 (3mm - 12mm)	1.654	4.00	2.42	MEC13-□	MEN13	MGR42	18,000	8.49					
-5			5.00	3.42				18,000	9.26					
-6			6.00	4.42				16,000	10.58					
-8			8.00	6.50				12,000	12.79					

1. Mega E Nut is included. Collet and wrench must be ordered separately.
2. Weight does not include collet.
3. Designed to be capable of supplying coolant through spindle or flange.
4. The "max" allowable spindle speed listed in the table is directly influenced by the rigidity of the machine and balance of the cutting tool. Therefore, the "max" allowable speed may not always be achievable.

※ Bores on Form B are sealed with set screws on delivery.

For MEGA E COLLET [PG. 22](#)

For MEGA WRENCH [PG. 22](#)

For MEGA E NUT [PG. 22](#)

For ADJUSTING SCREW [PG. 22](#)

MEGA E CHUCK® Coolant-Through Hole

Clamping Range: $\varnothing.125'' - \varnothing.500''$ ($\varnothing3\text{mm} - \varnothing12\text{mm}$)



- Model Description
B | **BT30** - **MEGA** | **6** | **E** - **50**
 - BT Shank No.
 - Mega Chuck Series
 - Mega E Chuck
 - Max Capacity (mm)
 - L= Projection Length (mm)
- BIG-PLUS® System

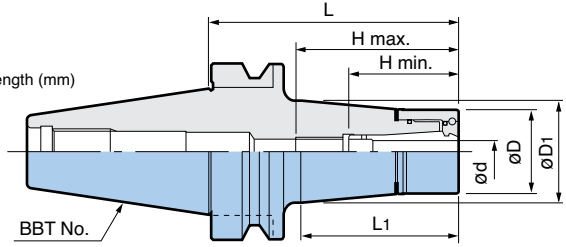

BT SHANK BBT30/40 MAS403

BIG-PLUS® tools can be used in machining centers with conventional spindles.

Model	$\varnothing d$	$\varnothing D$	$\varnothing D1$	L	L1	H		Collet Model	Nut	Wrench	Max. RPM	Weight (lbs)
						min.	max.					
BBT30-MEGA6E-50	.125 - .250 (3mm - 6mm)	.984	1.01	1.97	.98	1.46	2.17	MEC6-□	MEN6	MGR25	40,000	1.17
-75											35,000	1.41
-90											25,000	1.59
-105											25,000	1.81
-MEGA8E-50	.125 - .250 (3mm - 8mm)	1.181	1.20	1.97	.98	1.65	2.40	MEC8-□	MEN8	MGR30	40,000	1.24
-75											35,000	1.57
-90											25,000	1.83
-105											25,000	2.12
-MEGA10E-50	.125 - .375 (3mm - 10mm)	1.378	1.39	1.97	.98	1.89	2.76	MEC10-□	MEN10	MGR35	39,000	1.33
-75											35,000	1.77
-90											25,000	2.06
-105											25,000	2.34
-MEGA13E-50	.125 - .500 (3mm - 12mm)	1.654	1.67	1.97	1.08	1.97	2.87	MEC13-□	MEN13	MGR42	38,000	1.44
-75											34,000	1.99
-90											25,000	2.32
-105											25,000	2.65
BBT40-MEGA6E-60	.125 - .250 (3mm - 6mm)	.984	1.03	2.36	1.10	1.46	2.17	MEC6-□	MEN6	MGR25	30,000	2.39
-75			1.13	2.95	1.65						30,000	2.52
-90			1.23	3.54	2.24						30,000	2.67
-105			1.33	4.13	2.83						29,000	2.85
-120			1.44	4.72	3.43						29,000	3.12
-135			1.54	5.31	3.98						27,000	3.38
-165			1.75	6.50	5.16						20,000	4.09
-200			2.00	7.87	6.57						15,000	5.13
-MEGA8E-60	.125 - .250 (3mm - 8mm)	1.181	1.22	2.36	1.10	1.65	2.40	MEC8-□	MEN8	MGR30	30,000	2.50
-75			1.31	2.95	1.65						30,000	2.67
-90			1.42	3.54	2.24						30,000	2.87
-105			1.52	4.13	2.83						29,000	3.23
-120			1.63	4.72	3.43						29,000	3.56
-135			1.73	5.31	4.02						27,000	3.89
-165			1.93	6.50	5.20						20,000	4.64
-200			2.20	7.87	6.69						15,000	5.59
-MEGA10E-60	.125 - .375 (3mm - 10mm)	1.378	1.42	2.36	1.14	1.89	2.76	MEC10-□	MEN10	MGR35	30,000	2.72
-75			1.51	2.95	1.65						30,000	2.96
-90			1.61	3.54	2.24						30,000	3.23
-105			1.72	4.13	2.83						29,000	3.56
-120			1.82	4.72	3.43						29,000	3.93
-135			1.92	5.31	4.02						27,000	4.38
-165			2.14	6.50	5.28						22,000	5.24
-200			2.19	7.87	6.69						16,000	6.78
-MEGA13E-60	.125 - .500 (3mm - 12mm)	1.654	1.68	2.36	1.14	1.97	2.95	MEC13-□	MEN13	MGR42	30,000	2.85
-75			1.77	2.95	1.65						30,000	3.20
-90			1.89	3.54	2.32						30,000	3.60
-105			1.99	4.13	2.91						29,000	4.07
-120			2.10	4.72	3.54						29,000	4.57
-135			2.20	5.31	4.13						26,000	5.17
-165			2.26	6.50	5.31						22,000	6.19
-200			2.46	7.87	6.69						16,000	7.98

1. Mega E Nut is included. Collet and wrench must be ordered separately.
 2. Weight does not include collet.
 3. Designed to be capable of supplying coolant through spindle.

4. The "max" allowable spindle speed listed in the table is directly influenced by the rigidity of the machine and balance of the cutting tool. Therefore, the "max" allowable speed may not always be achievable.

MEGA E COLLET

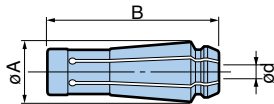

- Model Description
- | | | | | |
|-----|---|---|-----|----|
| MEC | 6 | - | 1/8 | AA |
|-----|---|---|-----|----|
- Collet Class
 - Clamping Size
 - Body Size
 - Mega E Collet

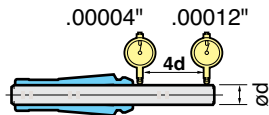

Collet Class	T.I.R.	
	At nose	At end of test bar
AA	Within .00004"	Within .00012"

Use only a cutting tool shank with exactly the same diameter as collet bore diameter. The tolerance of the cutting tool shank must be within h7.

MEGA6E		
	Clamping Size ϕd	Model
INCH SIZE	.125	MEC6-1/8AA
	.187	-3/16AA
	.250	-1/4AA
METRIC SIZE	3.0	MEC6-3AA
	4.0	-4AA
	5.0	-5AA
	6.0	-6AA

$\phi A = .44$ B = 1.37

MEGA8E		
	Clamping Size ϕd	Model
INCH SIZE	.125	MEC8-1/8AA
	.187	-3/16AA
	.250	-1/4AA
METRIC SIZE	3.0	MEC8-3AA
	4.0	-4AA
	5.0	-5AA
	6.0	-6AA
	7.0	-7AA
	8.0	-8AA

$\phi A = .56$ B = 1.55

MEGA10E		
	Clamping Size ϕd	Model
INCH SIZE	.125	MEC10-1/8AA
	.187	-3/16AA
	.250	-1/4AA
	.312	-5/16AA
	.375	-3/8AA
METRIC SIZE	3.0	MEC10-3AA
	4.0	-4AA
	5.0	-5AA
	6.0	-6AA
	7.0	-7AA
	8.0	-8AA
	9.0	-9AA
	10.0	-10AA

$\phi A = .67$ B = 1.80

MEGA13E			
	Clamping Size ϕd	Model	
INCH SIZE	.125	MEC13-1/8AA	
	.187	-3/16AA	
	.250	-1/4AA	
	.312	-5/16AA	
	.375	-3/8AA	
	.437	-7/16AA	
	.500	-1/2AA	
METRIC SIZE	3.0	MEC13-3AA	
	4.0	-4AA	
	5.0	-5AA	
	6.0	-6AA	
	7.0	-7AA	
	8.0	-8AA	
	9.0	-9AA	
	10.0	-10AA	
		12.0	-12AA

$\phi A = .81$ B = 1.89

Accessories (Need to be ordered separately)

Mega E Chuck	Mega Wrench	Collet	Adjusting Screw	Rubber		
	Model	Model	Model	G	L	B (mm)
MEGA6E	MGR25	MEC6-□	NBA6B	M7	.47	2
MEGA8E	MGR30	MEC8-□	NBA8B	M9	.51	2.5
MEGA10E	MGR35	MEC10-□	NBA10B	M11	.63	3
MEGA13E	MGR42	MEC13-□	NBA13B	M14	.79	4

Spare Parts

Mega E Nut
Model
MEN6
MEN8
MEN10
MEN13

MEGA DOUBLE POWER CHUCK® Coolant-Through Hole

Clamping Range: \varnothing .625" - \varnothing 1.500"

Simultaneous fit is achieved on the nut as well as the taper shank to obtain rigidity close to an integral body.

**MAX
30,000
RPM**



- Model Description
- B** | **CV40** - **MEGA** | **.625** | **DS** - **3.5**
- L= Projection Length (in)
- Double Power Chuck
- Clamping Size (in)
- Mega Chuck Series
- CAT Shank No.
- BIG-PLUS® System

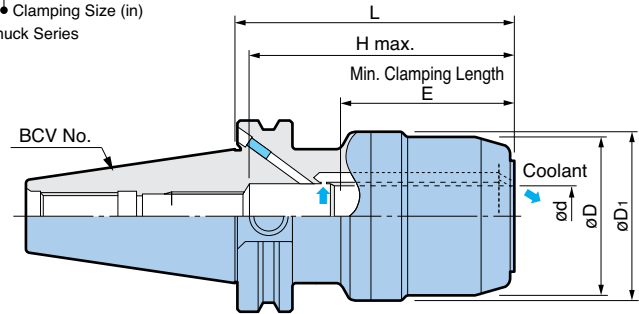

※ Coolant bores in accordance to DIN69871/Form B

Plug Screw for flange through coolant

For details of plug screws, please refer to [PG. 14](#)

CAT SHANK BCV40/50 ASME B5.50-1994

BIG-PLUS® tools can be used in machining centers with conventional spindles.

Model	\varnothing d	\varnothing D	\varnothing D1	L	H	Min. Clamping Length E	Wrench	Max. RPM	Weight (lbs)
BCV40-MEGA.625DS-3.5	.625	1.81	2.17	3.59	2.88	2.1	MGR46	30,000	3.31
-MEGA.750DS-3.5	.750	2.17	2.19	3.59	3.44	2.3	MGR55	30,000	3.97
-MEGA1.000DS-3.5	1.000	2.44	2.47	3.59	3.44	2.3	MGR62	27,000	4.41
-MEGA1.250DS-4	1.250	2.76	2.47	4.09	3.63	2.7	MGR70	26,000	5.07
BCV50-MEGA.625DS-4	.625	1.81	2.48	4.09	2.88	2.1	MGR46	21,000	8.82
-6				6.09				19,000	10.80
-MEGA.750DS-4	.750	2.36	2.72	4.09	3.44	2.3	MGR60	20,000	9.92
-6				6.09				17,000	13.01
-MEGA1.000DS-4	1.000	2.76	3.03	4.09	3.63	2.7	MGR70	20,000	10.58
-6				6.09				17,000	14.33
-MEGA1.250DS-4	1.250	3.15	3.39	4.09	4.22	2.9	MGR80	20,000	11.25
-6				6.09				15,000	15.88
-MEGA1.500DS-4.5	1.500	3.90	3.93	4.50	4.29	2.9	MGR99	15,000	14.55

1. Wrench must be ordered separately.
 2. The "max" allowable spindle speed listed in the table is directly influenced by the rigidity of the machine and balance of the cutting tool. Therefore, the "max" allowable speed may not always be achievable.
 3. Tools w/ flats should not be used in Mega Double Power Chucks.
- ※ Bores on Form B are sealed with set screws on delivery.

For **ADJUSTING SCREW** [PG. 25](#)

For **PSC COLLET** [PG. 25](#)

For **STRAIGHT COLLET** [PG. 25](#)

For **MEGA WRENCH** [PG. 25](#)



- Model Description
- B** | **CV40** | **H** | **MEGA** | **.625** | **DS** | **- 3.5**
- L= Projection Length (in)
- Double Power Chuck
- Clamping Size (in)
- Mega Chuck Series
- High Power Type
- CAT Shank No.
- BIG-PLUS® System

This type does not conform to ASME B5.50-1994 standard for safe zone. Interference with tool changer may occur.

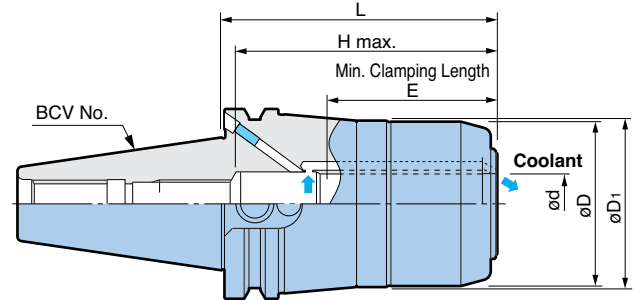

※Coolant bores in accordance to DIN69871/Form B

Plug Screw for flange through coolant
For details of plug screws, please refer to [PG. 14](#)

CAT SHANK BCV40H/50H ASME B5.50-1994

BIG-PLUS® tools can be used in machining centers with conventional spindles.

Model	ød	øD	øD1	L	H max.	Min. Clamping Length E	Wrench	Max. RPM	Weight (lbs)
BCV40H-MEGA.625DS-3.5	.625	1.81	2.17	3.59	2.88	2.1	MGR46	30,000	3.31
-MEGA.750DS-3.5	.750	2.17	2.19	3.59	3.44	2.3	MGR55	30,000	3.97
-MEGA1.000DS-3.5	1.000	2.44	2.47	3.59	3.44	2.3	MGR62	27,000	4.41
-MEGA1.250DS-4	1.250	2.76	2.79	4.09	3.63	2.7	MGR70	26,000	5.07
BCV50H-MEGA.750DS-4	.750	2.36	2.72	4.09	3.44	2.3	MGR60	20,000	9.92
-6				6.09				17,000	13.01
-MEGA1.000DS-4	1.000	2.76	3.03	4.09	3.63	2.7	MGR70	20,000	10.58
-6				6.09				17,000	14.33
-MEGA1.250DS-4	1.250	3.15	3.39	4.09	4.22	2.9	MGR80	20,000	11.25
-6				6.09				15,000	15.88
-MEGA1.500DS-4.5	1.500	3.90	3.93	4.59	4.29	2.9	MGR99	15,000	14.55

1. Wrench must be ordered separately.
2. The "max" allowable spindle speed listed in the table is directly influenced by the rigidity of the machine and balance of the cutting tool. Therefore, the "max" allowable speed may not always be achievable.

3. Tools w/ flats should not be used in Mega Double Power Chucks.
- ※ Bores on Form B are sealed with set screws on delivery.

- Model Description
- B** | **BT30** | **MEGA** | **.750** | **DS** | **- 2.5**
- L= Projection Length (in)
- Double Power Chuck
- Clamping Size (in)
- Mega Chuck Series
- BT Shank No.
- BIG-PLUS® System

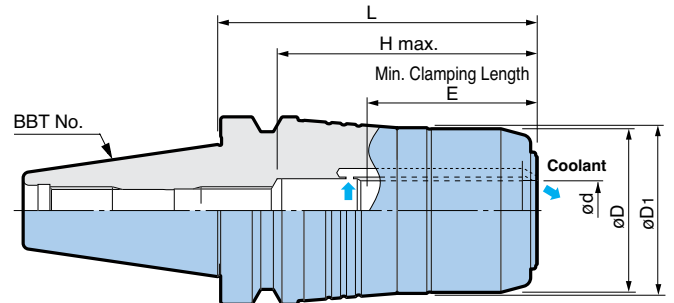

BT SHANK BBT30/40/50 MAS403

BIG-PLUS® tools can be used in machining centers with conventional spindles.

Model	ød	øD	øD1	L	H max.	Min. Clamping Length E	Wrench	Max. RPM	Weight (lbs)
BBT30-MEGA.750DS-2.5	.750	1.96	1.99	2.59	2.39	2.1	MGR50	30,000	2.00
BBT40-MEGA.625DS-3	.625	1.81	2.17	3.09	2.88	2.1	MGR46	30,000	3.53
-5				5.09				25,000	6.17
-MEGA.750DS-3	.750	2.17	2.19	3.09	3.44	2.3	MGR55	30,000	3.75
-5				5.09				25,000	5.95
-MEGA1.000DS-3.5	1.000	2.44	2.47	3.59	3.44	2.3	MGR62	27,000	4.41
-5				5.09				24,000	6.61
-MEGA1.250DS-3.5	1.250	2.76	2.79	3.59	3.32	2.7	MGR70	26,000	4.63
-5				5.09				22,000	6.84
BBT50-MEGA.750DS-4	.750	2.36	2.72	4.09	3.44	2.3	MGR55	20,000	9.95
-MEGA1.000DS-4	1.000	2.76	3.03	4.09	3.63	2.7	MGR62	20,000	10.60
-MEGA1.250DS-4	1.250	3.15	3.39	4.09	4.22	2.9	MGR70	20,000	11.30
-MEGA1.500DS-4.5	1.500	3.90	3.93	4.59	4.29	2.9	MGR99	15,000	14.60

1. Wrench must be ordered separately.
2. The "max" allowable spindle speed listed in the table is directly influenced by the rigidity of the machine and balance of the cutting tool. Therefore, the "max" allowable speed may not always be achievable.

3. Tools w/ flats should not be used in Mega Double Power Chucks.

MEGA DOUBLE POWER CHUCK®

ACCESSORIES

ADJUSTING SCREW

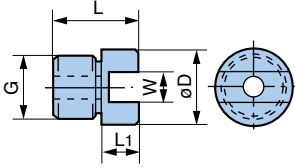

Model	øD	L	L1	G	W	Mega DS Chuck Model
HMA-M16	.748	1.063	.236	M16P1.5	.315	BCV/BBT-MEGA.750DS
						BCV/BBT-MEGA1.000DS
HMA-M16S	.748	1.063	.236	M16P1.5	.394	BCV/BBT40-MEGA1.250DS
HMA-M24	1.181	1.417	.374	M24P1.5	.394	BCV/BBT50-MEGA1.250DS
						BCV/BBT50-MEGA1.500DS

PSC COLLET PAT.

High Precision

For coolant-through tools

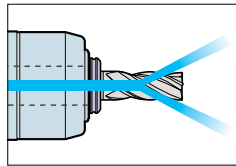

- Model Description
- PSC** | **.75** - **1/4**
- Inner Dia. (in)
- Outer Dia. (in)
- Perfect Seal Collet

OIL HOLE COLLET

Model	Mega DS Chuck Model
PSC.750-1/4, 3/8, 1/2, 5/8	MEGA.750DS
PSC1.25-1/2, 5/8, 3/4, 7/8, 1	MEGA1.250DS

STRAIGHT COLLET (Type "C")

Reduction sleeve for smaller diameter cutters.



- Model Description
- C** | **.75** - **1/4**
- Inner Dia. (in)
- Outer Dia. (in)
- Collet Type

	Model	Mega DS Chuck Model
INCH SIZE	C.75-1/4, 5/16, 3/8, 7/16, 1/2, 9/16, 5/8	MEGA.750DS
	C1.00-1/4, 3/8, 1/2, 5/8, 3/4	MEGA1.000DS
	C1.25-1/4, 5/16, 3/8, 7/16, 1/2, 9/16, 5/8, 11/16, 3/4, 13/16, 7/8, 15/16, 1	MEGA1.250DS
METRIC SIZE	C.75-6, 8, 9, 10, 12, 16	MEGA.750DS
	C1.25-12, 14, 16, 20, 25	MEGA1.250DS

MEGA WRENCH PAT.

US Patent No. 5596913

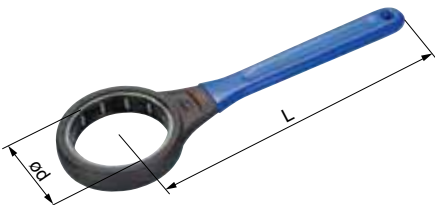

- Model Description
- MGR** | **46**
- Inner Dia. of Wrench (mm)
- Mega Wrench

Model	ød	L	Body
MGR46	1.81	7.087	BCV40□/BCV50/BBT40-MEGA.625DS
MGR50	1.96	7.087	BBT30-MEGA.750D S
MGR55	2.17	7.874	BCV40□/BBT40-MEGA.750DS
			BBT50-MEGA.750DS
MGR60	2.36	9.055	BCV50□ MEGA.750DS
MGR62	2.44	9.055	BCV40□/BBT40-MEGA1.000DS
			BBT50-MEGA1.000DS
MGR70	2.76	9.843	BCV40□/BBT40-MEGA1.250DS
			BCV50□ MEGA1.000DS
MGR80	3.15	11.024	BBT50-MEGA1.250DS
			BCV50□ MEGA1.250DS
MGR99	3.90	11.614	BCV50□ MEGA1.500DS
			BBT50-MEGA1.500DS

END MILL HOLDER



- Model Description
- B** CV40 - **EM** .500 - **3**
- L = Length (in)
- Clamping Size (in)
- End Mill Holder
- CAT Shank No.
- BIG-PLUS® System

CAT SHANK BCV40/50 ASME B5.50-1994

BIG-PLUS® tools can be used in machining centers with conventional spindles.

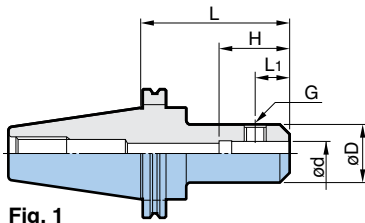

Fig. 1

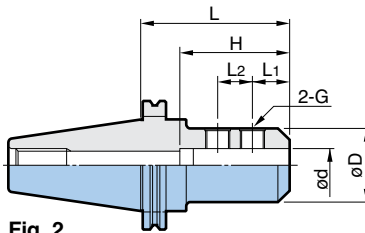

Fig. 2

Model	Fig.	ød	øD	L	L1	L2	H	G
BCV40-EM.500-3	1	.500	1.375	3.00	.874	-	3.000	7/16" - 20
-4.5				4.50				
-EM.625-3				3.00				
-4.5	1	.625	1.625	4.50	.937	-	3.500	9/16" - 18
-EM.750-3				3.00				
-4.5	1	.750	1.750	4.50	1.000	-	3.875	5/8" - 18
-EM1.000-3				3.00				
-4.5	2	1.000	2.252	4.50	1.125	1.000	3.125	3/4" - 16
-EM1.250-4.5				4.50				
-EM1.500-5				5.00				
BCV50-EM.500-4.5	1	.500	1.375	4.50	.874	-	3.000	7/16" - 20
-6				6.00				
-EM.625-4.5				4.50				
-6	1	.625	1.625	6.00	.937	-	3.500	9/16" - 18
-EM.750-4.5				4.50				
-6	1	.750	1.750	6.00	1.000	-	3.875	5/8" - 18
-EM1.000-4.5				4.50				
-6	2	1.000	2.252	6.00	1.125	1.000	3.125	3/4" - 16
-8				8.00				
-EM1.250-4.5				4.50				
-6	2	1.250	2.750	6.00	1.125	1.000	3.125	3/4" - 16
-8				8.00				
-EM1.500-4.5				4.50				
-6	2	1.500	2.750	6.00	1.125	1.000	3.125	3/4" - 16
-8				8.00				
-EM2.000-6				8.00				
-6	2	2.000	3.500	6.00	1.375	1.375	4.330	1" - 14
-8				8.00				

1. For high speed applications, Mega Double Power Chucks are recommended instead of End Mill Holders.

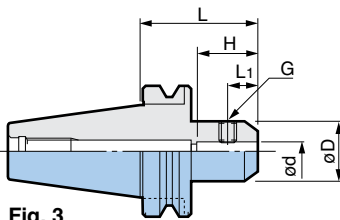

Fig. 3

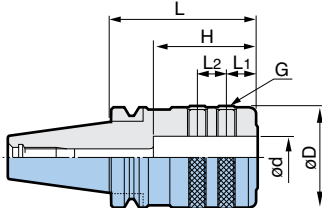

Fig. 4

BT SHANK BBT30/40 MAS403

BIG-PLUS® tools can be used in machining centers with conventional spindles.

Model	Fig.	ød	øD	L	L1	L2	H	G
BBT30-EM.250-2.5	3	.250	.875	2.50	.438	-	1.10	1/4" - 28
-EM.375-2.5					.750		1.77	3/8" - 24
-EM.500-2.5					.874		3.00	7/16" - 20
-EM.625-2.5					.937		2.69	9/16" - 18
-EM.750-3					1.000		2.75	5/8" - 18
BBT40-EM.500-3	3	.500	1.375	3.00	.874	-	3.00	7/16" - 20
-EM.625-3					.937		3.50	9/16" - 18
-EM.750-4					1.000		3.875	5/8" - 18
-EM1.000-4	4	1.000	2.252	4.50	1.125	1.000	3.125	3/4" - 16
-EM1.250-4								

1. For high speed applications, Mega Double Power Chucks are recommended instead of End Mill Holders.

SPARE PARTS SET SCREW



Holder	Part No.	Thread Size
EM.250	11.690.517	1/4" - 28
EM.375	11.690.518	3/8" - 24
EM.500	11.690.519	7/16" - 20
EM.625	11.690.520	9/16" - 18
EM.750	11.690.521	5/8" - 18

Holder	Part No.	Thread Size
EM1.000	11.690.522	3/4" - 16
EM1.250	11.690.522	3/4" - 16
EM1.500	11.690.522	3/4" - 16
EM2.000	11.690.524	1" - 14

SHELL MILL ADAPTER

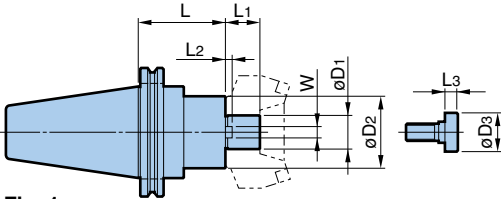

Fig. 1

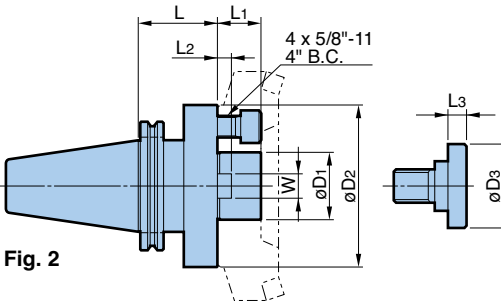

Fig. 2

• Model Description

- B** **CV40** - **SM** **.750** - **2**
- L= Length (in)
 - O.D. of Pilot (in)
 - Shell Mill Adapter
 - CAT Shank No.
 - BIG-PLUS® System

CAT SHANK BCV40/50 ASME B5.50-1994

BIG-PLUS® tools can be used in machining centers with conventional spindles.

Model	Fig	øD1	øD2	øD3	L	L1	L2	L3	W				
BCV40-SM.750-2	1	.750	1.689	.875	2.00	.689	.156	.375	.313				
-4					4.00								
-6					6.00								
-SM1.000-2		1.000	2.189	1.118	2.00								
-4					4.00								
-6					6.00								
-SM1.250-2	1	1.250	2.752	1.500	2.00	.281	.500	.500					
-SM1.500-2		1.500	3.626	1.875	2.00				.929	.375	.625		
BCV50-SM.750-2	1	.750	1.689	.875	2.00	.689	.156	.375	.313				
-4					4.00								
-6					6.00								
-SM1.000-2		1	1.000	2.189	1.118					2.00	.219	.375	.375
-4										4.00			
-6										6.00			
-8	8.00												
-10*	10.00												
-12*	12.00												
-SM1.250-2	1	1.250	2.752	1.500	2.00	.281	.500	.500					
-4					4.00								
-6					6.00								
-8					8.00								
-10					10.00								
-12					12.00								
-SM1.500-2	1	1.500	3.626	1.875	2.00	.375	.500	.625					
-4					4.00								
-6					6.00								
-8					8.00								
-10					10.00								
-12					12.00								
-SM2.000-2	2	2.000	4.874	2.500	2.00	.438	.750	.750					
-4					4.00								
-SM2.500-2.5	2	2.500	4.874	3.125	2.50	1.126		1.000					

1. For high speed applications, Shell Mill Adapters should be balanced together with the cutters.

2. * Tapered body for increased rigidity.

BT SHANK BBT30/40 MAS403

BIG-PLUS® tools can be used in machining centers with conventional spindles.

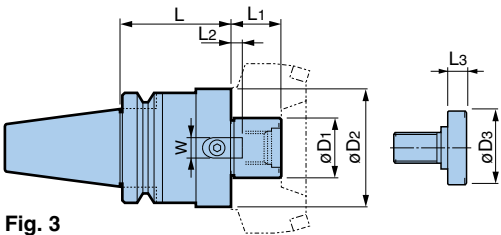

Fig. 3

Model	Fig	øD1	øD2	øD3	L	L1	L2	L3	W						
BBT30-SM.750-2	3	.750	1.689	.875	2.00	.689	.156	.375	.313						
-SM1.000-2										1.000	2.189	1.118	.219	.375	.375
BBT40-SM.750-2	3	.750	1.689	.875	2.00	.689	.156	.375	.313						
-SM1.000-2										1.000	2.189	1.118	.219	.375	.375
-SM1.250-2										1.250	2.752	1.500	.281	.500	.500
-SM1.500-2										1.500	3.626	1.875	.375	.500	.625
													.929		

1. For high speed applications, Shell Mill Adapters should be balanced together with the cutters.

SPARE PARTS

LOCK SCREW



Adapter	Part No.	Thread Size
SM.750	11.690.710	3/8" - 24
SM1.000	11.690.711	1/2" - 20
SM1.250	11.690.712	5/8" - 18
SM1.500	11.690.713	3/4" - 16
SM2.000	11.690.714	1" - 14
SM2.500	11.690.715	1" - 14

SHRINK FIT HOLDER

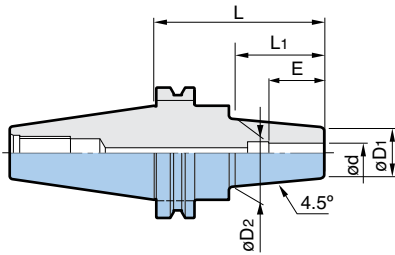

• Model Description

B **CV40** - **SF** **.250** - **3.5**

- L= Length (in)
- Clamping Size (in)
- Shrink Fit Holder
- CAT Shank No.
- BIG-PLUS® System

CAT SHANK BCV40/50 ASME B5.50-1994

BIG-PLUS® tools can be used in machining centers with conventional spindles.

Model	ød	øD1	øD2	L	L1	E
BCV40-SF.250-3.5	.250	.787	1.063	3.50	.639	.866
-SF.375-3.5	.375	.945	1.260			1.220
-SF.500-3.5	.500					1.417
-6				6.00		
-SF.625-3.5	.625	1.063	1.339	3.50	.639	1.535
-6				6.00		
-SF.750-4	.750	1.299	1.654	4.00		
-6				6.00	.822	1.850
-SF1.000-4	1.000	1.732	2.087	4.00		
-6				6.00		
BCV50-SF.500-4	.500	.945	1.260	4.00	.730	1.417
-SF.625-4	.625	1.063	1.339	4.00	.639	1.535
-SF.750-4	.750	1.299	1.654	4.00	.822	1.614
-6				6.00		
-SF1.000-4				4.00		
-6	1.000	1.732	2.087	6.00	.822	1.850
-6				6.00		
-SF1.250-4	1.250			4.00		
-6				6.00		2.008

BT SHANK BBT40 MAS403

BIG-PLUS® tools can be used in machining centers with conventional spindles.

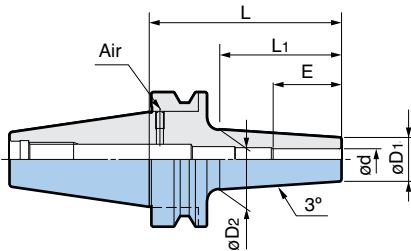

Model	ød	øD1	øD2	L	L1	E
BBT40-SF.250-3.5	.250	.787	1.063	3.500	2.40	.866
-SF.375-3.5	.375	.945	1.260			1.220
-SF.500-3.5	.500	.945	1.260			1.417
-SF.625-3.5	.625	1.063	1.339	4.000	2.90	1.535
-SF.750-4	.750	1.299	1.654			1.850
-SF1.000-4	1.000	1.732	2.087			1.850

1. Metric sizes available upon request.

BLANK BAR



• Model Description

B **CV40** - **BB** **2.500** - **8**

- L= Length (in)
- Diameter (in)
- Blank Bar
- CAT Shank No.
- BIG-PLUS® System

CAT SHANK BCV40/50 ASME B5.50-1994

BIG-PLUS® tools can be used in machining centers with conventional spindles.

Model	øD	L
BCV40-BB2.500-8	2.500	8.000
-BB4.000-6	4.000	6.000
BCV50-BB4.000-8	4.000	8.000
-BB6.000-8	6.000	

1. Do not heat treat after machining.

ER COLLET CHUCK

Coolant-Through Hole

Clamping Range: ϕ .020" - ϕ .787"

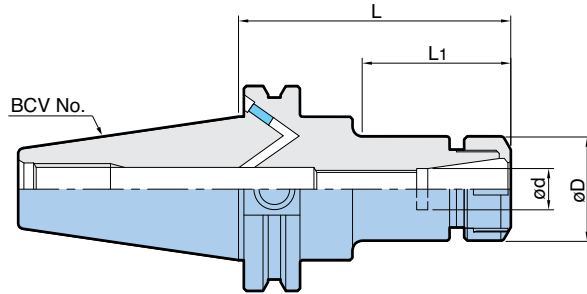
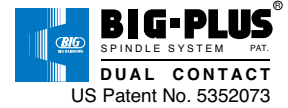

• Model Description

B **CV40** - **ER** **16** - **2.5**

- L= Projection Length (in)
- Collet Size
- ER Collet Chuck Series
- CAT Shank No.
- BIG-PLUS® System

※Coolant bores in accordance to DIN69871/Form B

Plug Screw for flange through coolant

For details of plug screws, please refer to [PG. 14](#)

BCV40

BIG-PLUS® tools can be used in machining centers with conventional spindles.

Model	ϕd	ϕD	L	L ₁	Collet	Nut	Wrench
BCV40-ER16-2.5	.020 - .394	1.102	2.50	1.125	ER16	ERN16	ERK16
-4			4.00	2.625			
-6			6.00	4.625			
BCV40-ER32-3	.078 - .787	1.968	3.00	1.625	ER32	ERN32	ERK32
-4			4.00	2.625			
-6			6.00	4.625			

BCV50

BIG-PLUS® tools can be used in machining centers with conventional spindles.

Model	ϕd	ϕD	L	L ₁	Collet	Nut	Wrench
BCV50-ER16-3.5	.020 - .394	1.102	3.50	2.125	ER16	ERN16	ERK16
-5			5.00	3.625			
-6			6.00	4.625			
BCV50-ER32-3.5	.078 - .787	1.968	3.50	2.125	ER32	ERN32	ERK32
-5			5.00	3.625			
-6			6.00	4.625			

1. Nut is included. Wrench must be ordered separately.
 2. Collet not sold by BIG Kaiser.
 3. Designed to be capable of supplying coolant through spindle or flange.
- ※ Bores on Form B are sealed with set screws on delivery.

FULLCUT MILL FCR TYPE

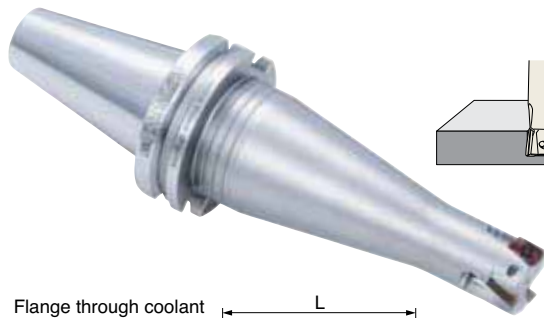

Shoulder milling

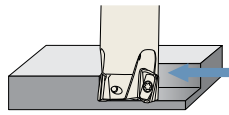

Ramping

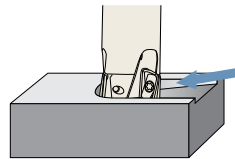

Helical milling

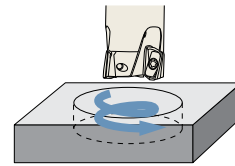

Plunge milling

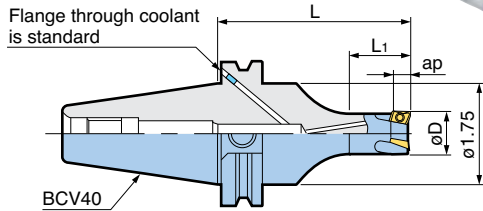
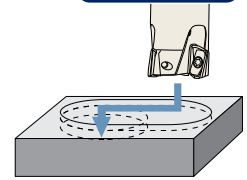

※ Coolant bores in accordance to DIN69871/Form B

Plug Screw for flange through coolant

For details of plug screws, please refer to [PG. 14](#)

Model Description

- B** | **CV40** | **-FCR** | **.625** | **-3.5**
- L= Length (in)
 - Diameter (in)
 - FCR Type
 - CAT Shank No.
 - BIG-PLUS® System

CAT SHANK BCV40 INCH STYLE ASME B5.50-1994

BIG-PLUS® tools can be used in machining centers with conventional spindles.

Model	øD	ap	L	L1	No. of Inserts	Insert
BCV40-FCR.625-3.5	.625	.315	3.50	.98	2	BRG16...
-5			5.00	1.18		
-5.5			5.50	.98		
-FCR.750-3.5	.750	.315	3.50	1.38	3	BRG20...
-5			5.00	1.18		
-5.5			5.50	1.18		
-FCR1.000-3.5	1.000	.315	3.50	1.58	3	BRG25...
-5			5.00	1.77		
-5.5			5.50	1.38		
-FCR1.250-3.5	1.250	.394	3.50	1.77	3	BRG32...
-5			5.00	1.97		
-5.5			5.50	1.58		

1. ap= Length of effective cutting edge.
2. Inserts are ordered separately.

※ Bores on Form B are sealed with set screws on delivery.

INDEXABLE INSERT



Model Description

- BRG16** | **08** | **08** | **ACZ350S**
- FCR Type
 - Nose Radius .031= 08, .125= 32
 - Effective Cutting Length
ø.625-1.000= 08mm
ø1.250= 10mm
 - Grade

Marking Description



Cutter Dia	Insert Model	ap	Nose Radius	P	M	K	N	
				ACZ350S		ACZ310	DC20	DS20
				General Steel	Stainless Steel	Cast Iron	Aluminum	
.625	BRG160808	.315	.031	○	○	○	○	○
.750	BRG200808	.315	.031	○	○	○	○	○
1.000	BRG250808	.315	.031	○	○	○	○	○
1.250	BRG321008	.394	.031	○	○	○	○	○
	BRG321032	.394	.125	○	○	○	○	○

1. Inserts are available in packets of 10 pcs.
2. Please clarify the insert type and grade when ordering.
For example, use ordering code: BRG160808ACZ350S.

⚠ Caution

Fullcut Mill uses a different insert for each cutter diameter.
If an incorrect insert is used, a problem will result.

There is no compatibility with those of FCM Type.

Adapter for CAT50/BT50 Taper Shank

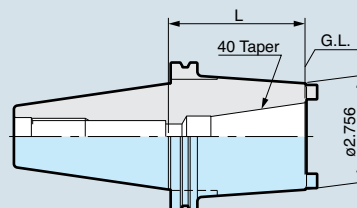
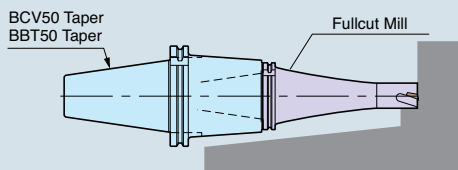

Model	L
BCV50-BCV40-2	1.969
-4	3.543
BBT50-BBT40-50	1.969
-90	3.543

FULLCUT MILL FCM TYPE

Higher rigidity with integral body with dual contact system.



Flange through coolant is standard option

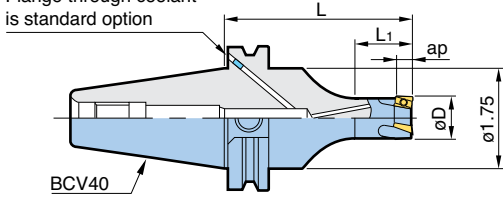

※Coolant bores in accordance to DIN69871/Form B

Plug Screw for flange through coolant

For details of plug screws, please refer to [PG. 14](#)

• Model Description

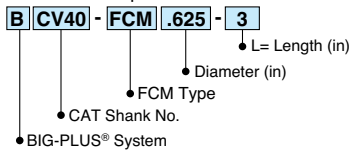

CAT SHANK BCV40 INCH STYLE ASME B5.50-1994

BIG-PLUS® tools can be used in machining centers with conventional spindles.

Model	øD	ap	L	L1	No. of Inserts	Insert
BCV40-FCM.625-3	.625	.354	3.00	1.00	2	ARG16...
-4			4.00	1.25		
-5			5.00	1.00		
-FCM.750-3	.750	.354	3.00	1.00	3	ARG20...
-4			4.00	1.25		
-5			5.00	1.00		
-FCM1.000-3	1.000	.354	3.00	1.00	3	ARG25...
-5			5.00	1.75		
-6			6.00	1.50		
-FCM1.250-3	1.250	.433	3.00	1.25	3	ARG32...
-5			5.00	2.25		
-6			6.00	1.75		
-FCM1.500-3	1.500	.433	3.00	1.50	4	ARG40...
-5			5.00	2.50		
-6			6.00	2.00		
-FCM2.000-3	2.000	.433	3.00	2.25	5	ARG40...
-5			5.00	4.25		
-6			6.00	5.25		

1. ap= Length of effective cutting edge.

2. Inserts are ordered separately.

※ Bores on Form B are sealed with set screws on delivery.

[For ADAPTER PG. 30](#)

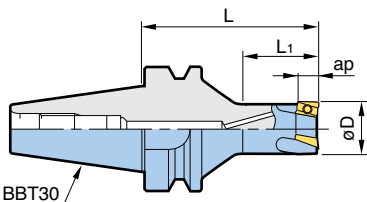

• Model Description

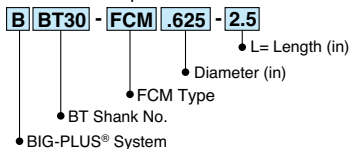

BT SHANK BBT30 INCH STYLE MAS403

BIG-PLUS® tools can be used in machining centers with conventional spindles.

Model	øD	ap	L	L1	No. of Inserts	Insert
BBT30-FCM.625-2.5	.625	.354	2.5	1.0	2	ARG16...
-FCM.750-2.5	.750		2.5	1.2	3	ARG20...
-FCM1.000-2.5	1.000		2.5	1.4	3	ARG25...
-FCM1.250-2.5	1.250	.433	2.5	1.6	3	ARG32...
-FCM1.500-2	1.500		2.0	1.0	4	ARG40...
-FCM2.000-2	2.000		2.0	1.1	5	

1. ap= Length of effective cutting edge.

2. Inserts are ordered separately.



Note

The integral version of the Fullcut Mill provides increased rigidity as a result of the reduced gauge length. It is particularly recommended for use in machines having a small spindle taper. Additionally, there is a cost savings as no chuck is necessary.

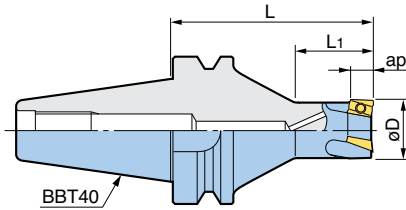

• Model Description

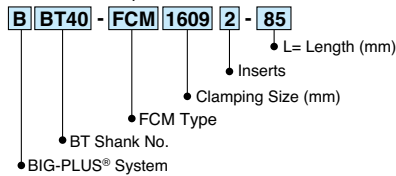

BT SHANK BBT40 METRIC STYLE MAS403

BIG-PLUS® tools can be used in machining centers with conventional spindles.

Model	øD (inch)	ap	L	L1	No. of Inserts	Insert
BBT40-FCM16092- 85	16mm (.630)	.354	3.35	.91	2	ARG16...
-105			4.13	1.18		
-120			4.72	.98		
-150			5.91			
-FCM20093- 85	20mm (.787)	.354	3.35	1.10	3	ARG20...
-105			4.13	1.38		
-120			4.72	1.18		
-150			5.91			
-FCM25093- 85	25mm (.984)	.354	3.35	1.30	3	ARG25...
-120			4.72	1.77		
-135			5.32	1.58		
-165			6.50			
-FCM32113- 85	32mm (1.260)	.433	3.35	1.50	3	ARG32...
-120			4.72	2.36		
-135			5.32	1.97		
-165			6.50	1.58		
-FCM40114- 85	40mm (1.575)	.433	3.35	1.69	4	ARG40...
-120			4.72	2.56		
-135			5.32	2.36		
-165			6.50	1.97		
-FCM50115- 70	50mm (1.969)	.433	2.76	1.50	5	ARG40...
-120			4.72	2.56		
-135			5.32	2.36		
-165			6.50	1.97		

1. ap= Length of effective cutting edge.
2. Inserts are ordered separately.

For ADAPTER PG. 30

INDEXABLE INSERT



• Model Description

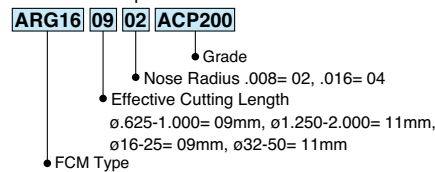

Marking Description

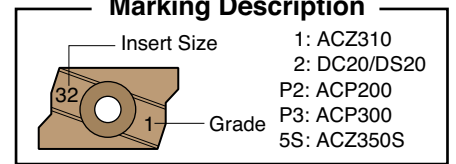

Cutter Dia		Insert Model	ap	Nose Radius	P		M	K	N	
in	mm				ACP200 General Steel	ACP300 Hardened Steel	ACZ350S Stainless Steel	ACZ310 Cast Iron	DC20 Aluminum	DS20 Aluminum
.625	16	ARG160902	.354	R0.2 (.008)		○	○	○	○	
		ARG160904		R0.4 (.016)	○	○	○		○	
.750	20	ARG200902	.354	R0.2 (.008)		○	○	○	○	
		ARG200904		R0.4 (.016)	○	○	○		○	
1.000	25	ARG250902	.354	R0.2 (.008)		○	○	○	○	
		ARG250904		R0.4 (.016)	○	○	○		○	
1.250	32	ARG321102	.433	R0.2 (.008)		○	○	○	○	
		ARG321104		R0.4 (.016)	○	○	○		○	
1.500 2.000	40 50	ARG401102	.433	R0.2 (.008)		○	○	○	○	
		ARG401104		R0.4 (.016)	○	○	○		○	

1. Inserts are available in packets of 10 pcs.
2. Please clarify the insert type and grade when ordering.
For example, use ordering code: ARG160902ACP200.

Caution

Fullcut Mill uses a different insert for each cutter diameter (except for dia. 1.500" and 2.000").
If an incorrect insert is used, a problem will result.
There is no compatibility with those of FCR Type.

FULLCUT MILL FCR/FCM TYPE

SPARE PARTS

Cutter Dia.		Insert		Insert Clamping Screw Set	Wrench	Anti-seizure Lubricant
in	mm	FCR	FCM	Model	Model	Model
.625	16	BRG160808	ARG1609 <input type="checkbox"/>	S2506DS	DA-T8	BN-5
.750	20	BRG200808	ARG2009 <input type="checkbox"/>			
1.000	25	BRG250808	ARG2509 <input type="checkbox"/>			
1.250	32	BRG3210 <input type="checkbox"/>	ARG3211 <input type="checkbox"/>	S3508DS	DA-T15	
1.500	40	—	ARG4011 <input type="checkbox"/>			
2.000	50	—	ARG4011 <input type="checkbox"/>			



Note

It is recommended to regularly replace clamping screws and wrench to ensure the correct clamping force is maintained.

CUTTING DATA RECOMMENDATIONS

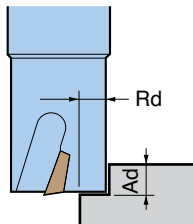

Ad: Axial D.O.C.
ap: Cutting Edge Length
Rd: Radial D.O.C.

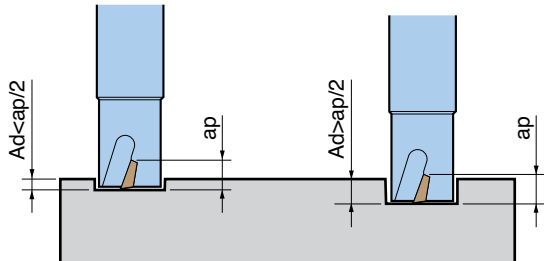

Finish or Light Milling- $Ad < ap/2$

Material	øD	Insert Grade	Speed SFM	Feed IPT	
				Full Slot	Rd<1/2D
Low or Medium Carbon Steel, Unalloyed or Low Alloy Steel 1020, A36, 8620, 4140	.625	FCR: ACZ350S FCM: ACP300	300 - 620	.002 - .004	.003 - .005
	.750 - 1.000		300 - 690	.002 - .005	.003 - .006
	1.250 - 1.500		330 - 820	.003 - .007	.004 - .008
	2.000			.003 - .008	.004 - .010
High Carbon Steel, High Alloy Tool Steel 01, H13, D2, A2, M2, P20	.625	FCR: ACZ350S FCM: ACP300	300 - 620	.002 - .004	.003 - .005
	.750 - 1.000		300 - 650	.002 - .005	.003 - .006
	1.250 - 1.500		330 - 760	.002 - .007	.003 - .008
	2.000			.002 - .008	.003 - .009
Hardened Steel Rc<40	.625	ACP200	260 - 460	.003 - .004	.003 - .004
	.750 - 1.000		260 - 460	.003 - .004	.003 - .004
	1.250 - 1.500		260 - 460	.003 - .005	.003 - .005
	2.000		260 - 460	.003 - .005	.003 - .005
Stainless Steel 303, 304, 316, 420	.625	ACZ350S	230 - 580	.003 - .006	.003 - .007
	.750 - 1.000		230 - 650	.004 - .007	.004 - .008
	1.250 - 1.500		330 - 650	.004 - .008	.004 - .009
	2.000			.004 - .008	.004 - .010
Cast Iron	.625	ACZ310	300 - 580	.002 - .005	.003 - .006
	.750 - 1.000		300 - 620	.002 - .006	.003 - .007
	1.250 - 1.500		330 - 700	.003 - .007	.003 - .008
	2.000		330 - 720	.003 - .008	.003 - .010
Aluminum	.625	DC20 DS20	660 - 5000	.003 - .008	.004 - .010
	.750 - 1.000			.004 - .010	.004 - .012
	1.250 - 1.500			.004 - .012	.004 - .014
	2.000			.004 - .014	.004 - .016

Formulas: $RPM = \frac{SFM \times 3.82}{D}$ $IPM = IPT \times RPM \times \text{No. of teeth}$

APPLICATION EXAMPLES

(All of the following application examples are achieved with dry cutting)

● Large nose radius



After end milling for a distance of 200 feet, a fine surface finish of R_y 4.3m was achieved and maintained, including the corner radius.

Fullcut Mill FCR	BCV40-FCR1.250-3.5	Cutting Speed V	1,650 SFM
Insert	BRG321030(DS20)	Feed Rate f	.006 IPT
Work Material	Aluminum / Air blow	Axial DOC Ad (in)	.350



● Bore ϕ 1.5" with helical milling



In 1050 carbon steel, very smooth cutting with a feed rate of 43 IPM and excellent squareness are achieved.

Fullcut Mill FCR	BBT40-FCR20083-120	Cutting Speed V	492 SFM
Insert	BRG200808(ACZ350S)	Feed Rate f	43 IPM
Work Material	1050 / Air blow	Axial DOC Ad (in)	.079

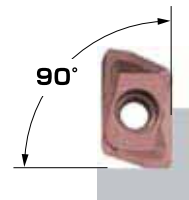

● Honeycombed pocket with ramping



In a low rigidity workpiece with .12" thickness clamped by a vise, a feed rate of 169 IPM on both sides of the workpiece is achieved.

Fullcut Mill FCR	BBT40-FCR20083-85	Cutting Speed V	2,461 SFM
Insert	BRG200808(DS20)	Feed Rate f	169 IPM
Work Material	Aluminum / Air blow	Axial DOC Ad (in)	.236 (3 times)

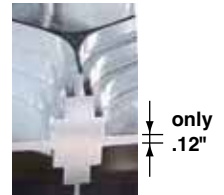

● Slot milling



Only the Fullcut Mill was capable of achieving this data with a 40 taper machine.

Fullcut Mill FCM	BBT40-FCM32113-85
Insert	ARG321104(ACP300)
Work Material	1055 carbon steel
Cutting Speed V	500 SFM
Feed Rate f	.005 IPT
Axial DOC Ad (in)	.35



● High speed milling of aluminum

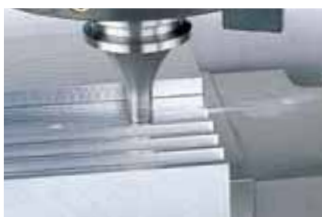

Efficient chip evacuation and excellent surface finish.

Fullcut Mill FCM	BBT40-FCM16092-85
Insert	ARG160904(DS20)
Work Material	Aluminum
Cutting Speed V	1970 SFM
Feed Rate f	.006 IPT
Axial DOC Ad (in)	.35



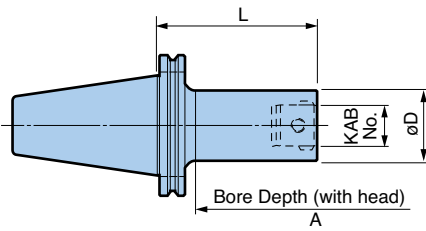

- Model Description
- B** | **CV40** | x | **KA4** | x | **D3.1**
- Bore Depth (with head)
- KA Size
- CAT Shank No.
- BIG-PLUS® System

CAT SHANK BCV40/50 ASME B5.50-1994

BIG-PLUS® tools can be used in machining centers with conventional spindles.

Catalog Number	Model	KAB No.	øD	L	A	Weight (lbs)
11.368.441	BCV40xKA4xD3.1	KAB4	1.535	2.874	3.150	3.0
11.368.444	xKA4xD6.3			6.024	6.300	5.0
11.368.451	xKA5xD3.1			2.480	3.150	3.0
11.368.454	xKA5xD6.3	KAB5	1.968	5.630	6.300	6.0
11.368.462	xKA6xD3.9			2.716	3.937	3.0
11.368.464	xKA6xD6.3	KAB6	2.491	5.079	6.300	6.5
11.368.642	BCV50xKA4xD3.9			3.611	3.937	8.0
11.368.644	xKA4xD6.3	KAB4	1.535	6.026	6.300	8.3
11.368.645	xKA4xD7.8			7.589	7.875	8.8
11.368.652	xKA5xD3.9	KAB5	1.968	3.268	3.937	7.5
11.368.654	xKA5xD6.3			5.630	6.300	9.2
11.368.655	xKA5xD7.8			7.205	7.875	11.0
11.368.656	xKA5xD10.2			9.567	10.236	12.8
11.368.662	xKA6xD3.9			2.716	3.937	7.6
11.368.664	xKA6xD6.3	KAB6	2.491	5.079	6.300	10.5
11.368.665	xKA6xD7.8			6.654	7.875	13.0
11.368.666	xKA6xD10.2			9.016	10.236	15.8
11.368.667	xKA6xD12.6			11.378	12.598	18.5
11.368.674	xKA7xD6.3	KAB7	3.543	3.268	6.300	9.8
11.368.675	xKA7xD8.0			5.315	8.548	15.7
11.368.676	xKA7D10.2			7.205	10.236	21.0

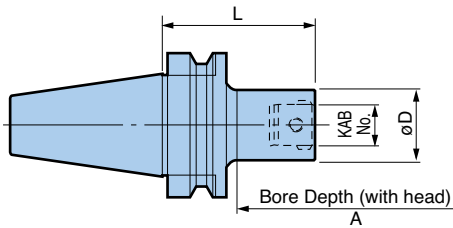

- Model Description
- B** | **BT30** | x | **KA3** | x | **D2.1**
- Bore Depth (with head)
- KA Size
- BT Shank No.
- BIG-PLUS® System

BT SHANK BBT30/40/50 MAS403

BIG-PLUS® tools can be used in machining centers with conventional spindles.

Catalog Number	Model	KAB No.	øD	L	A	Weight (lbs)
11.368.030	BBT30xKA3xD2.1	KAB3	1.220	1.535	2.086	1.1
11.368.040	xKA4xD2.3	KAB4	1.535	1.496	2.283	1.1
11.368.051	xKA5xD3.7	KAB5	1.968	2.480	3.543	1.8
11.368.061	xKA6xD3.7	KAB6	2.491	2.520	3.543	2.9
11.368.142	BBT40xKA4xD4.0	KAB4	1.535	3.485	4.000	3.0
11.368.152	xKA5xD4.0	KAB5	1.968	3.070	4.000	3.5
11.368.162	xKA6xD4.0	KAB6	2.491	2.520	4.000	3.7
11.368.343	BBT50xKA4xD4.8	KAB4	1.535	4.646	4.800	9.9
11.368.353	xKA5xD4.8	KAB5	1.968	4.250	4.800	10.2
11.368.363	xKA6xD4.8	KAB6	2.491	3.700	4.800	10.5
11.368.374	xKA6xD6.5	KAB7	3.543	3.661	6.500	15.8

Basic holder for
KAB BORING SYSTEM

For entire Kaiser Boring System,
please refer to catalog **No. 307A**

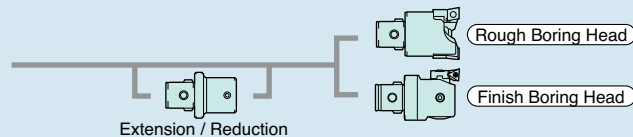
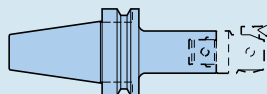

ABS SHANK BASIC HOLDER

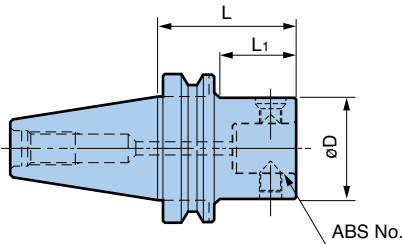

• Model Description

B **CV40** - **ABS50** - **75**

- L= Projection Length (mm)
- ABS No.
- CAT Shank No.
- BIG-PLUS® System

CAT SHANK BCV40/50 ASME B5.50-1994

BIG-PLUS® tools can be used in machining centers with conventional spindles.

Model	ABS No.	øD	L	L1	Weight (lbs)
BCV40-ABS50-75	50	1.969	2.953	2.203	2.8
-ABS63-90	63	2.480	3.543	2.793	3.5
BCV50-ABS40-60	40	1.575	2.362	.943	7.0
-ABS50-60	50	1.969	2.362	.943	7.1
-ABS63-80	63	2.480	3.150	2.400	7.7
-ABS80-100	80	3.150	3.937	3.187	10.0
-ABS100-125	100	3.937	4.921	4.171	15.0

BT SHANK BBT40/50 MAS403

BIG-PLUS® tools can be used in machining centers with conventional spindles.

Model	ABS No.	øD	L	L1	Weight (lbs)
BBT40-ABS50-60	50	1.969	2.362	1.220	3.1
-ABS63-70	63	2.480	2.756	1.693	4.0
BBT50-ABS80-100	80	3.150	3.937	2.362	12.5
-ABS100-110	100	3.937	4.331	2.835	15.4

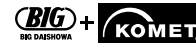

BIG Komet ABS is produced under the license from Komet in Germany, and maintains interchangeability with their products.

BIG COROMANT CAPTO BASIC HOLDER

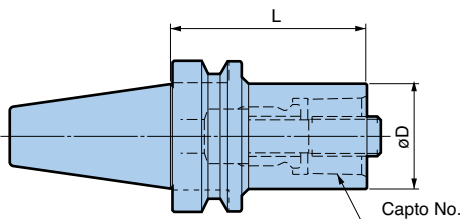

• Model Description

B **CV40** - **C5** - **3**

- L= Projection Length (in)
- Capto Size
- CAT Shank No.
- BIG-PLUS® System

CAT SHANK BCV40/50 ASME B5.50-1994

BIG-PLUS® tools can be used in machining centers with conventional spindles.

Model	Capto No.	øD	L	Weight (lbs)
BCV40-C5-3	C5	1.969	3.000	3.6
-C6-3.5	C6	2.480	3.500	4.2
BCV50-C5-1.5	C5	1.969	1.500	7.5
BCV50Y-C6-2	C6	2.480	2.000	7.5
BCV50Y-C8-3	C8	3.150	3.000	8.9

BT SHANK BBT40/50 MAS403

BIG-PLUS® tools can be used in machining centers with conventional spindles.

Model	Capto No.	øD	L	Weight (lbs)
BBT40-C5-50	C5	1.969	1.969	2.2
-C6-75	C6	2.480	2.953	3.6
BBT50-C5-40	C5	1.969	1.575	8.0
-C6-50	C6	2.480	1.969	7.3
-C8-70	C8	3.150	2.756	8.2

1. Y execution required for turning operations.

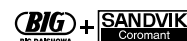

BIG Coromant Capto is produced under the license from AB Sandvik Coromant in Sweden, and maintains interchangeability with their products.

Revolutionary! – The very first modular tooling system for turning applications

A modular tooling system offers better efficiency, material selection, heat treatment and optimal tool lengths. The serious damage on tool holders caused by broken inserts can now be easily and economically replaced.

45° Tilt Style Type S



Coolant through

With "B" axis at 45°, accessibility problems with the chuck or tailstock are overcome to minimize tool length.

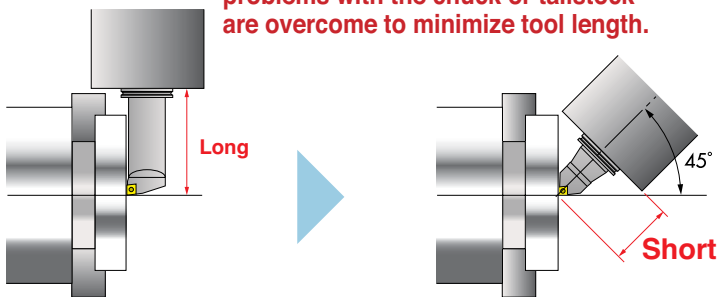

Tilting the "B" axis 45° helps to minimize the cutting forces transmitted to the machine spindle. This force reduction increases the life of the machine spindle.

17 kinds of Cartridge Type S for a variety of applications



Secure and rigid!! Type S Cartridge Clamping System

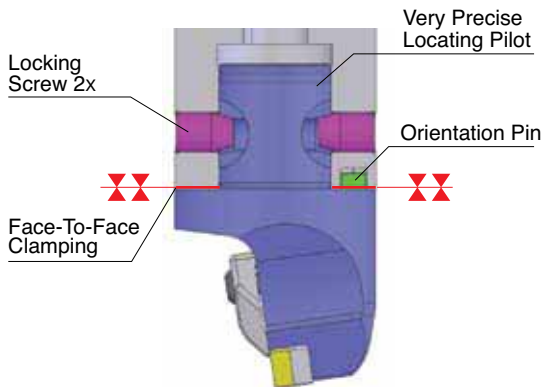

Using highly sophisticated and modern machine tools, Type S Cartridges are made to very close tolerances required for turning accuracy and repeatability. The cartridge is located in the basic holder by means of a precision ground pilot and secured by 2 opposing radial screws with a 15° taper. With a slight offset to locating sockets, high face-to-face clamping force of the two components is generated. To maintain precise locations and orientation, an additional locating pin is included for positive transfer of cutting torque.

90° Right Angle Style Type F



Coolant through

Center proximity type cartridge is also available, minimizing tailstock interference.

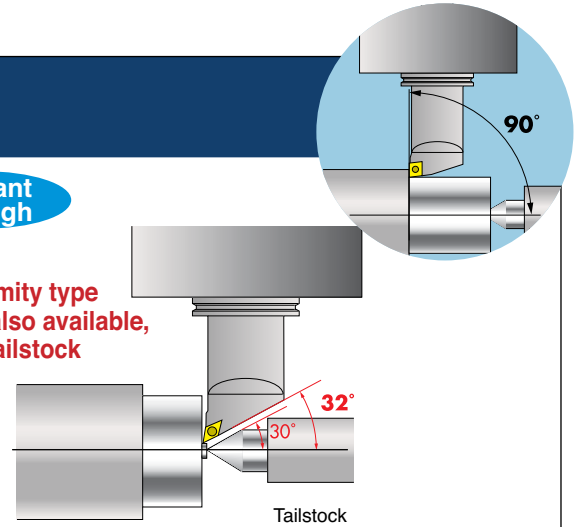

2 different basic holders are available and all can be assembled with either right or left hand version of cartridge.

24 kinds of Cartridge Type F for a variety of applications

Right and left hand cartridges are available



Simple and Positive Type F Cartridge Clamping System

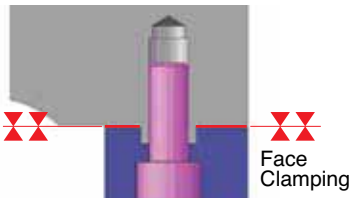
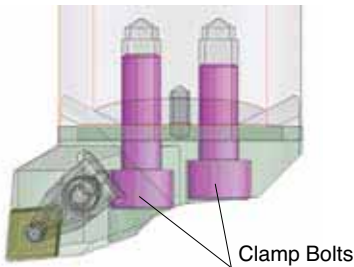

Type F uses 2 clamping bolts that presses the cartridge onto the basic holder. The torque is transmitted by an interlocking drive slot.

Precision Drive Keys

BIG-PLUS® turning tool holders are designed for Mill-Turn Machines. To maintain turning repeatability after tool change, the drive keys are precision milled after heat treat to prevent misalignment of cutting edge and centerline of workpiece.

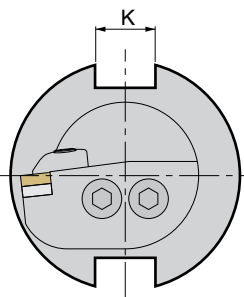

Range of Tolerance for Key Way

Model	ASME Standard Tolerance K	BIG-PLUS® Turning Tool Tolerance K
BCV40Y	.020	.0016
BCV50Y		.0020

1. Y execution required for turning operations.

TURNING TOOLS

45°

PG. 41 S50
TYPE S BASIC HOLDER

BCV40Y-S50-3
BCV50Y-S50-3.5
-S50-4.5



PG. 41
TYPE S CARTRIDGE

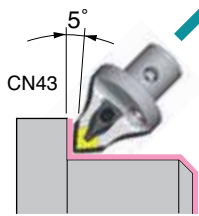
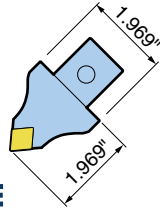

S50-DCLNN-00050-12

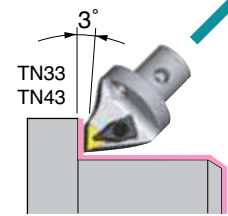

S50-DTJNR-00050-16
-DTJNL-00050-16
S50-DTJNR-00050-22
-DTJNL-00050-22

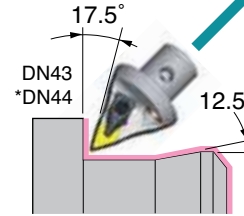

S50-DDHNN-00050-15

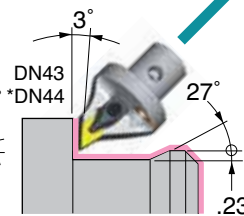

S50-DDJNR-00050-15
-DDJNL-00050-15

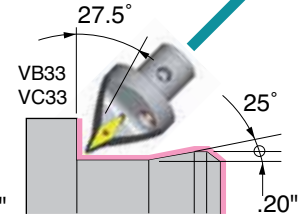

S50-SVQBN-00050-16

*In case of DN44 insert, please replace the standard carbide shim with DNS1506 (option).

90°

PG. 42 F63
TYPE F BASIC HOLDER

BCV40Y-F63-4.125
BCV50Y-F63-5.125

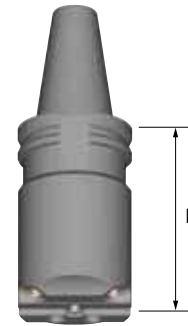

PG. 42
TYPE F CARTRIDGE

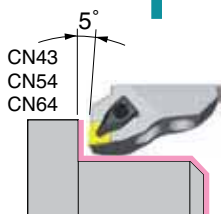
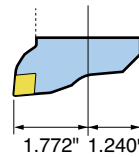

F63-DCLNR-45035-12(16)
-DCLNL-45035-12(16)
F63-PCLNR-45045-19
-PCLNL-45045-19

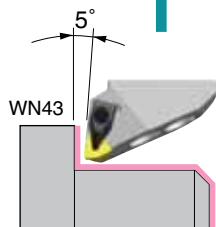

F63-DWLNR-45045-08
-DWLNL-45045-08

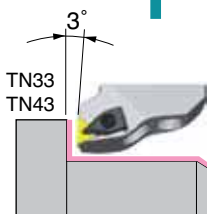

F63-DTJNR-45035-16(22)
-DTJNL-45035-16(22)

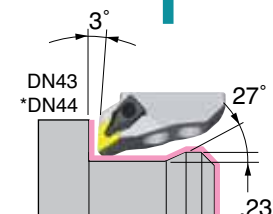

F63-DDJNR-45035-15
-DDJNL-45035-15

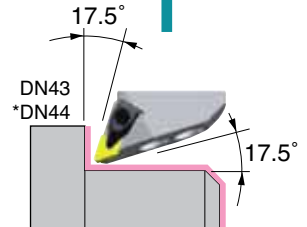

F63-DDHNR-45040-15
-DDHNL-45040-15

*In case of DN44 insert, please replace the standard carbide shim with DNS1506 (option).

PG. 41 S63
TYPE S BASIC HOLDER

BCV40Y-S63-2.625
 BCV50Y-S63-3.125
 -S63-4.125

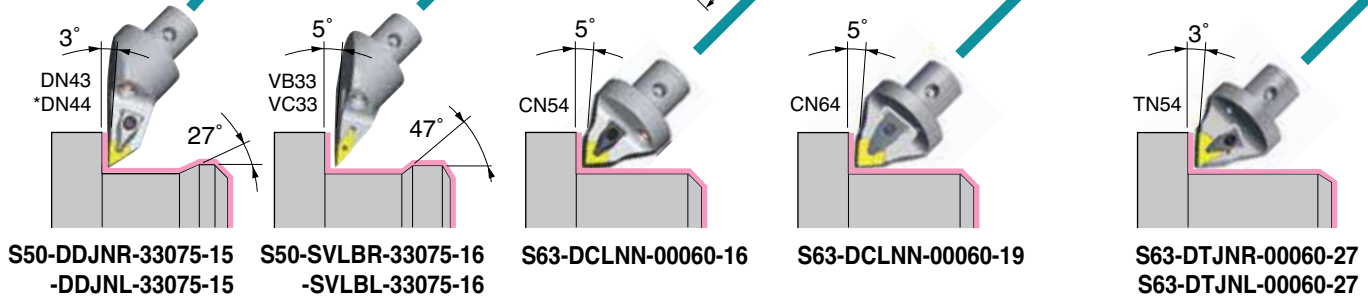
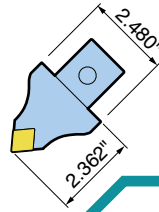
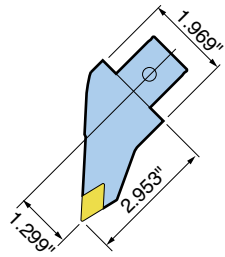

SQUARE TOOL HOLDER

PG. 43

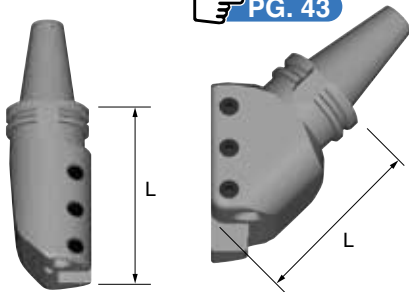

For □ Shank

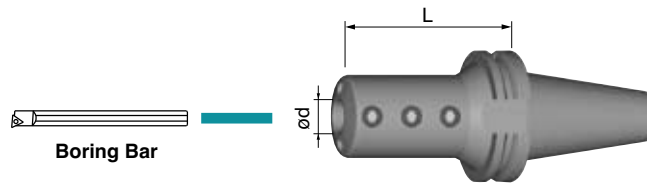

BORING BAR HOLDER

PG. 44

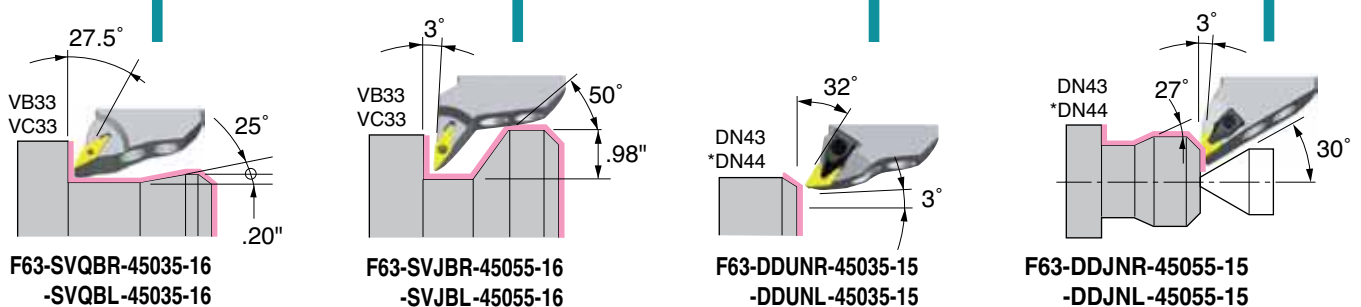

TURNING TOOLS

45° BASIC HOLDER TYPE S

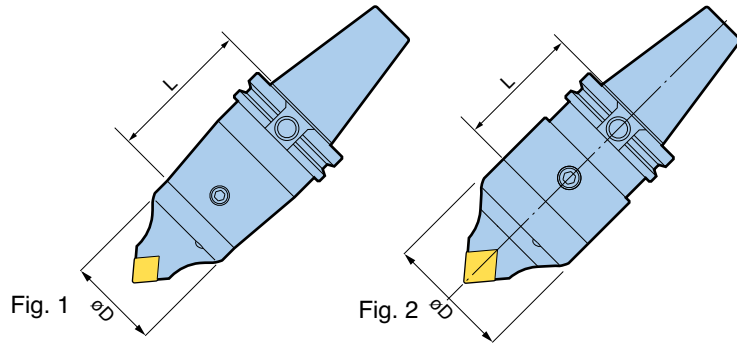

BIG-PLUS® tools can be used in machining centers with conventional spindles.

Type	Model	øD	L	Clamp Screw (2x)	Fig.
S50	BCV40Y-S50-3	1.969	3.000	10.690.435	1
S63	-S63-2.625	2.480	2.625	10.690.436	2
S50	BCV50Y-S50-3.5	1.969	3.500	10.690.435	1
	-S50-4.5		4.500		
S63	BCV50Y-S63-3.125	2.480	3.125	10.690.436	2
	-S63-4.125		4.125		

45° CARTRIDGE TYPE S

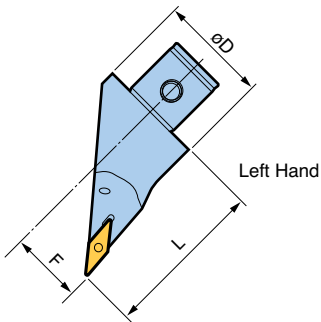
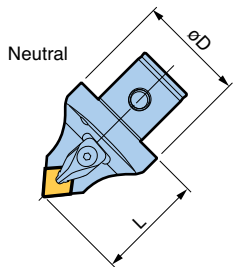

Lead Angle	Type	Hand	Model	Insert	L	F	øD	Clamp Piece
5°	S50	N	S50-DCLNN-00050-12	CN43 Rhombic 80°	1.969	0	1.969	CP2
	S63		S63-DCLNN-00060-16	CN54 Rhombic 80°	2.362			CP3
			S63-DCLNN-00060-19	CN64 Rhombic 80°				CP5
3°	S50	R	S50-DTJNR-00050-16	TN33 Triangle 60°	1.969	0	1.969	CP1
		L	-DTJNL-00050-16	TN43 Triangle 60°				CP2
		R	-DTJNR-00050-22					
	S63	L	-DTJNL-00050-22	TN54 Triangle 60°	2.362	2.480	CP3	
		R	S63-DTJNR-00060-27					
		L	-DTJNL-00060-27					
3°	S50	R	S50-DDJNR-00050-15	* DN43 DN44 Rhombic 55°	1.969	0	1.969	CP2
		L	-DDJNL-00050-15		2.953			
		R	-DDJNR-33075-15					
		L	-DDJNL-33075-15					
17.5°	S50	N	S50-DDHNN-00050-15		1.969	0		
5°	S50	R	S50-SVLBR-33075-16	VB33 VC33 Rhombic 35°	2.953	1.299	1.969	** M3.5
		L	-SVLBL-33075-16					
27.5°	S50	N	S50-SVQBN-00050-16		1.969	0		

1. Wrenches are not included with the cartridges. Please order separately.

2. Inserts are not included. Accepts ISO standard inserts.

3. * DN43 (3/16" thickness) carbide shim is included as standard.

In case of DN44 insert (1/4" thickness), please replace the standard carbide shim with DNS1506 (option).

4. ** M3.5 is screw-on type.

For SPARE PARTS PG. 45

Right Hand Left Hand Neutral

90° BASIC HOLDER TYPE F

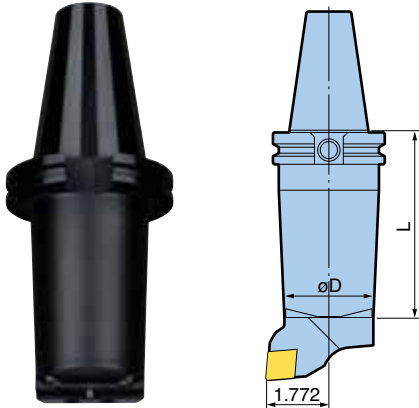

BIG-PLUS® tools can be used in machining centers with conventional spindles.

Type	Model	L	øD
F63	BCV40Y-F63-4.125	4.125	2.480
	BCV50Y-F63-5.125	5.125	

- Basic holders include M10x22L and M10x25L screws for clamping cartridges.
- Wrench is not included.

90° CARTRIDGE TYPE F

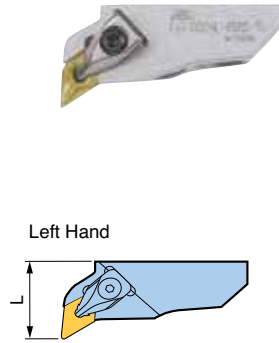

Lead Angle	Type	Hand	Model	Insert	L	Clamp Piece
5°	F63	R	F63-DCLNR-45035-12	CN43 Rhombic 80°	1.378	CP2
	F63	L	F63-DCLNL-45035-12			
	F63	R	F63-DCLNR-45035-16	CN54 Rhombic 80°	1.378	CP3
	F63	L	F63-DCLNL-45035-16			
	F63	R	F63-PCLNR-45045-19	CN64 Rhombic 80°	1.772	Lever Lock
	F63	L	F63-PCLNL-45045-19			
3°	F63	R	F63-DTJNR-45035-16	TN33 Triangle 60°	1.378	CP1
	F63	L	F63-DTJNL-45035-16			
	F63	R	F63-DTJNR-45035-22	TN43 Triangle 60°	1.378	CP2
	F63	L	F63-DTJNL-45035-22			
5°	F63	R	F63-DWLNR-45045-08	WN43 Hexagon	1.772	CP2
	F63	L	F63-DWLNL-45045-08			
3°	F63	R	F63-DDJNR-45035-15	* DN43 DN44 Rhombic 55°	1.378	CP2
	F63	L	F63-DDJNL-45035-15		2.165	CP2
	F63	R	F63-DDJNR-45055-15			
	F63	L	F63-DDJNL-45055-15			
17.5°	F63	R	F63-DDHNR-45040-15	1.575	1.575	CP2
	F63	L	F63-DDHNL-45040-15			
32°	F63	R	F63-DDUNR-45035-15	1.378	1.378	CP2
	F63	L	F63-DDUNL-45035-15			
27.5°	F63	R	F63-SVQBR-45035-16	VB33 VC33 Rhombic 35°	1.378	** M3.5
	F63	L	F63-SVQBL-45035-16			
3°	F63	R	F63-SVJBR-45055-16	2.165	2.165	M3.5
	F63	L	F63-SVJBL-45055-16			

- Wrenches are not included with the cartridges. Please order separately.
- Inserts are not included. Accepts ISO standard inserts.
- * DN43 (3/16" thickness) carbide shim is included as standard.
In case of DN44 insert (1/4" thickness), please replace the standard carbide shim with DNS1506 (option).
- ** M3.5 is screw-on type.

For SPARE PARTS PG. 45

Right Hand Left Hand

TURNING TOOLS

180° SQUARE TOOL HOLDER

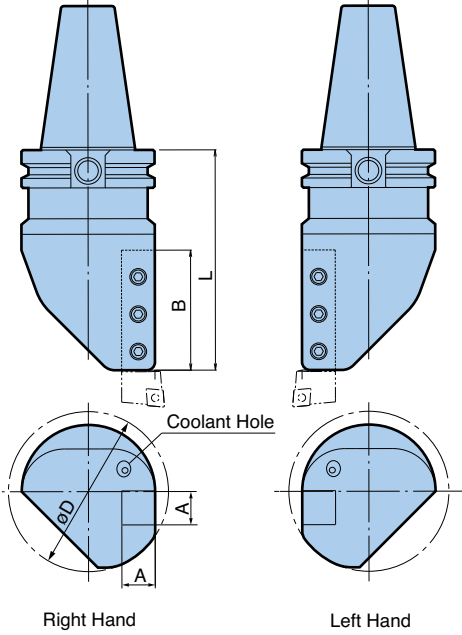

• Model Description

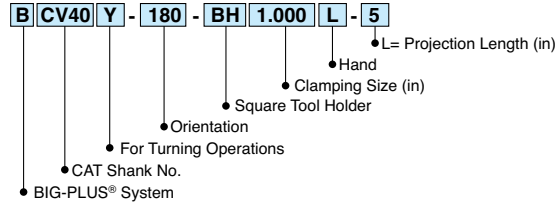

BIG-PLUS® tools can be used in machining centers with conventional spindles.

Model	Hand	A	L	B	ϕD
BCV40Y-180-BH1.000L-5	L	1.000	5.000	3.500	3.740
-180-BH1.000R-5	R				
BCV50Y-180-BH1.000L-5	L	1.000	5.000	3.421	4.921
-180-BH1.000R-5	R				
-180-BH1.250L-5	L	1.250		3.346	5.039
-180-BH1.250R-5	R				

Right Hand Left Hand

45° SQUARE TOOL HOLDER

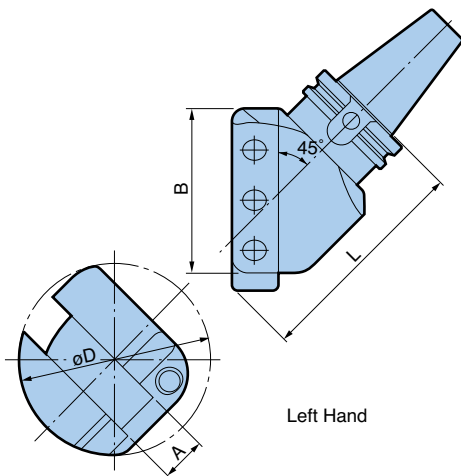

• Model Description

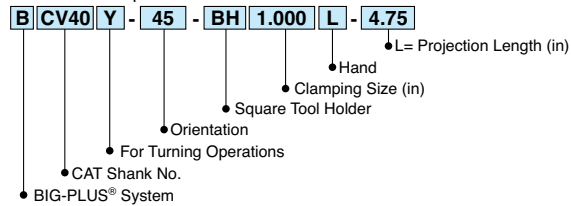

BIG-PLUS® tools can be used in machining centers with conventional spindles.

Model	Hand	A	L	B	ϕD
BCV40Y-45-BH1.000L-4.75	L	1.000	4.750	3.425	4.331
-45-BH1.000R-4.75	R				
BCV50Y-45-BH1.000L-5.5	L	1.000	5.500	3.345	5.315
-45-BH1.000R-5.5	R				
-45-BH1.250L-5.5	L	1.250	5.500	3.345	6.693
-45-BH1.250R-5.5	R				

Right Hand Left Hand

BORING BAR HOLDER

Clamping Range: ϕ .625" - ϕ 2.000"

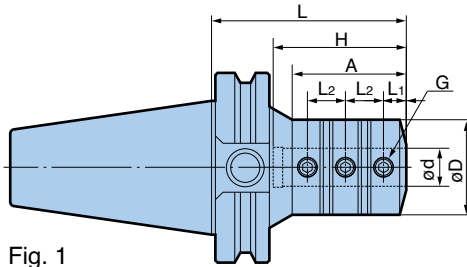

Fig. 1

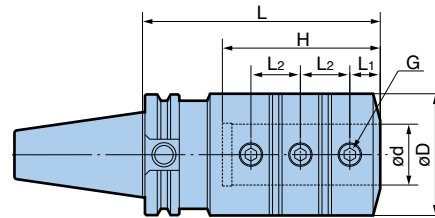

Fig. 2

• Model Description

- B** **CV40** **Y** - **BSL** **.625** - **3.5**
- L= Projection Length (in)
 - Clamping Size (in)
 - Boring Bar Holder
 - For Turning Operations
 - CAT Shank No.
 - BIG-PLUS® System

BIG-PLUS® tools can be used in machining centers with conventional spindles.

Model	Fig.	ød	øD	L	L1	L2	H	A	G
BCV40Y-BSL.625-3.5	1	.625	1.575	3.500	.394	.787	2.677	2.480	M10P1.25
-BSL.750-3.5		.750	1.929	3.500	.472	.787	2.520	2.559	
-BSL1.000-4		1.000	2.165	4.000	.551	.906	2.913	3.250	M12P1.5
-BSL1.250-5	2	1.250	2.520	5.000	.630	1.024	3.268	—	M16P1.5
-BSL1.500-5.5		1.500	3.150	5.500	.709	1.260	3.858	—	
BCV50Y-BSL.625-3.5	1	.625	1.575	3.500	.394	.827	2.717	2.480	M10P1.25
-BSL.750-3.5		.750	1.969	3.500	.472	.787	2.520	2.362	
-BSL1.000-4		1.000	2.165	4.000	.551	.906	2.913	2.756	M12P1.5
-BSL1.250-4.5		1.250	2.520	4.500	.394	1.024	3.268	3.346	
-BSL1.500-5		1.500	3.150	5.000	.709	1.260	3.858	4.094	M16P1.5
-BSL2.000-5.25		2.000	3.543	5.250	.709	1.417	4.528	4.500	

1. Interchangeable between center-through and side-through coolant supply by using plugs.
2. Plug A (1pc.) and Plug B (2 pcs.) are included as standard.

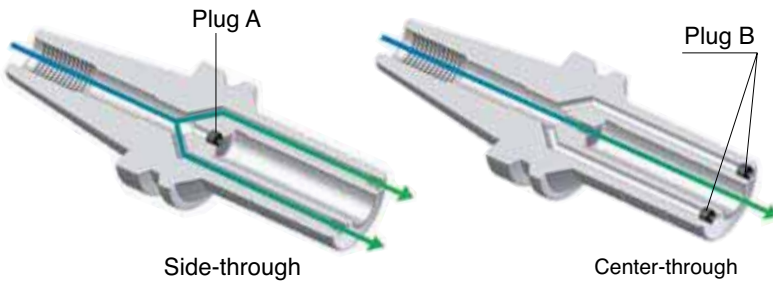

Adjustment for either right hand or left hand is also possible.

TURNING TOOLS

SPARE PARTS

DOUBLE CLAMP TYPE

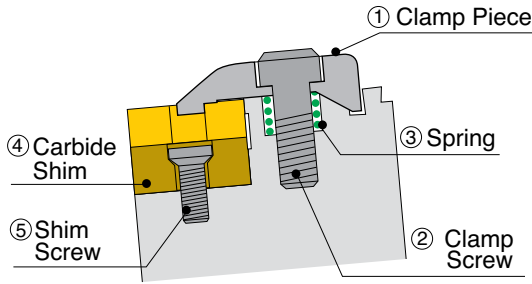

CLAMP PIECE SET

Set Model	① Clamp Piece	② Screw	③ Spring	Insert Size
SCP-1	CP1	M5x20	ø8x10	TN33
SCP-2	CP2			CN43, TN43 WN43, DN43, DN44
SCP-3	CP3			CN54, TN54
SCP-5	CP5			CN64

1. A set contains one clamp piece, screw and spring.
2. A wrench is not included, but available as an optional accessory (Model: T-4).

CARBIDE SHIM SET

Insert Size	Set Model	④ Carbide Shim	⑤ Screw	Torx Size
TN33	STNS1604	TNS1604	M3x7	T10
TN43	STNS2204	TNS2204	M4x8	T15
TN54	STNS2706	TNS2706	M5x12	T20
DN43	SDNS1504	DNS1504	M4x8	T15
DN44	SDNS1506	DNS1506	M4x8	T15

Insert Size	Set Model	④ Carbide Shim	⑤ Screw	Torx Size
CN43	SCNS1204	CNS1204	M4x8	T15
CN54	SCNS1606	CNS1606	M5x12	T20
CN64	SCNS1906	CNS1906	M5x12	T20
WN43	SWNS0804	WNS0804	M4x8	T15

1. A set contains one carbide shim and screw.
2. A wrench is not included. Please order separately (Model: DA-T10, DA-T15, DA-T20).

LEVER LOCK TYPE For F63-PCLNR(L)45045-19

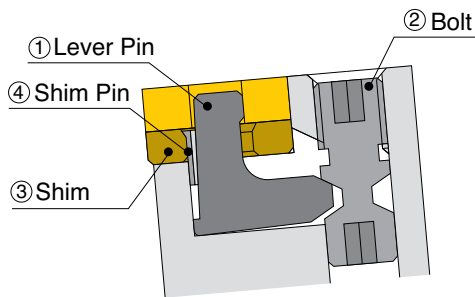

LEVER LOCK SET

Set Model	① Lever Pin	② Bolt	Spanner Size
SLCL6	LCL6	LCS6	4mm

CARBIDE SHIM SET

Set Model	③ Shim	④ Shim Pin
SLSC63	LSC63	LSC6

CLAMP SCREW

For Type S Basic Holder



Type	Screw Model	Screw Size	Wrench Model
S50	10.690.435	M10x1.0	10.690.816
S63	10.690.436	M12x1.0	10.690.817

INSERT CLAMPING SCREW SET

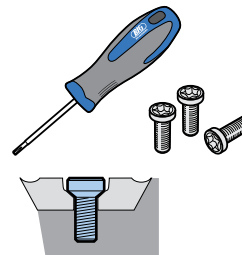

For VB33/VC33 Insert

Model	S3508DS
-------	---------

Contents

M3.5 screws.....10 pcs.
Wrench..... DA-T15 1 pc.

The BIG-PLUS® Spindle System is completely controlled by an exclusive gauge and measuring equipment, and achieves dual contact with interchangeability. Thus, it is necessary to have the gauge and measuring equipment below.

CAUTION

The BIG-PLUS® Spindle System is a patented technology developed by BIG Daishowa Seiki. The system requires high precision machining and grinding accuracy to maintain its universal interchangeability. Therefore, the gauge and the measuring equipment shown on this page are not allowed to be sold or loaned without an official license agreement with BIG Daishowa Seiki.

BIG-PLUS® MASTER GAUGE



This is the Master Ring Gauge Indicating the dimension between the gauge face and the spindle nose face.

This is the reference basis for BIG-PLUS® dimensional specification.

The gauges for BIG-PLUS® can be commonly used to measure a machine spindle other than MAS-BT standard, such as DIN, ISO, ASME (CAT) and ANSI standards.

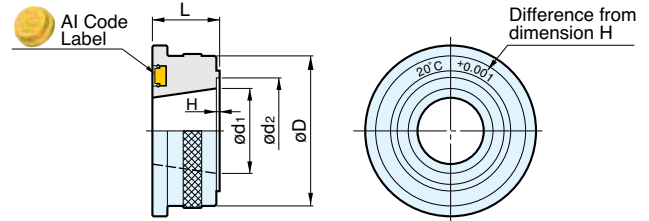

Model	ød1	ød2	øD	L
BBT30-MG	1.250	1.575	2.283	.98
BBT40-MG	1.750	2.165	3.150	1.38
BBT50-MG	2.750	3.543	4.921	1.97

BIG-PLUS® MEASUREMENT EQUIPMENT



This is the equipment used to measure the distance between the gauge line and the end face, which becomes the basis of BIG-PLUS®.

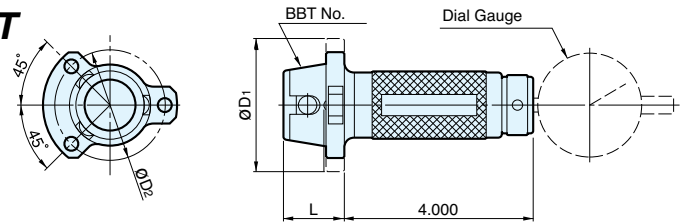

Model	øD1	øD2	L
BBT30-ME	2.205	1.693	1.024
BBT40-ME	2.835	2.323	1.280
BBT50-ME	4.331	3.740	1.693

BIG-PLUS® MASTER ARBOR



This is the arbor used to measure the axial movement of the holder on clamping, which is important for BIG-PLUS®.

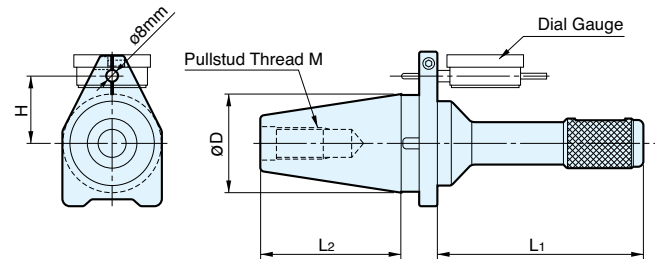

Model	øD	L1	L2	M	H
BBT30-MA	1.250	5.40	1.906	M12	.846
BBT40-MA	1.750	5.90	2.575	M16	1.161
BBT50-MA	2.750	5.90	4.008	M24	1.870

- The taper shank of the BIG-PLUS® Master Arbor is in accordance with MAS-BT standard (JIS standard). Therefore, please note that its taper shank length "L2", and the thread size "M" for pullstuds are different from the other standard, e.g. DIN, ISO, CAT and ANSI etc.
- If standard pullstuds are mounted on the BIG-PLUS® Master Arbor to measure spindles other than the MAS standard (JIS standard) spindles, axial movement of the holder will not be correct due to the variation of taper length. To compensate these differences, exclusive pullstuds must be used.

BIG-PLUS® TRADEMARK PLATE



This BIG-PLUS® trademark plate is provided by BIG Daishowa Seiki to authorized BIG-PLUS® licensees. Please be sure to install this plate onto machine tools made to BIG-PLUS® in order to prove authenticity and interchangeability.



Precision measuring tools of the highest quality for machine tool maintenance.

For maintaining the precision of your equipment to ensure a stable production environment.

The cause of machine tool runout stems from wear of the spindle bearings. Regular inspection with Dyna Test helps identify potential problems, and can reduce downtime and costly repairs of the machine tool spindle.

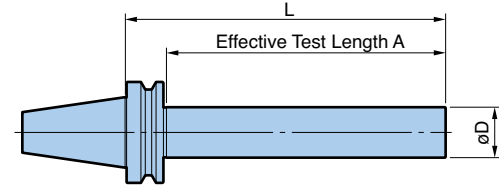

BCV Shank (ASME B5.50)

BIG-PLUS® tools can be used in machining centers with conventional spindles.

Model	L	A	øD
BCV40-2.000-L13.5SD	13.5	12.5	2
BCV50-2.000-L13.5SD	13.5	12.5	

1. Pullstud Bolt must be ordered separately. [UNIT: in]

BBT Shank (MAS403)

BIG-PLUS® tools can be used in machining centers with conventional spindles.

Model	L	A	øD
BBT30-32-L150	150	125	32
-L235	235	210	
BBT40-50-L200	200	170	50
-L350	350	320	
BBT50-50-L200	200	159	
-L360	360	319	

1. Pullstud Bolt must be ordered separately. [UNIT: mm]

Precision Standard of BIG Daishowa Test Arbors	
Runout	0.002mm (.00008")
Roundness	0.001mm (.00004")
Cylindricity	0.003mm (.00012")
Roughness	Ra: 0.1µm (.000004")
Taper Contact	AT1
Diameter Tol.	±0.005mm (.0002")

Calibration Certificate and Traceability System

BIG Daishowa can offer a Calibration Certificate with traceability on request as per ISO9000 requirements.

BIG Daishowa provides high quality best bars, produced under a strict quality control system.

Aluminum Case

An aluminum case is provided to protect and store the test bars.



Blowing air cleans the BIG-PLUS® machine spindle face of coolant, oil and dirt.

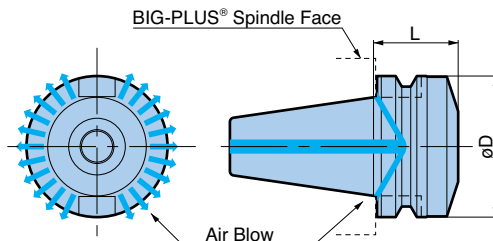

BCV Shank

Model	øD	L
SCV40-ASC-1.750T	2.480	1.750
SCV50-ASC-2.5T	3.875	2.480

BBT Shank

Model	øD	L
SBT30-ASC-30T	1.811	1.181
SBT40-ASC-40T	2.480	1.575
SBT50-ASC-60T	3.937	2.362

1. When the cleaner is clamped into a BIG-PLUS® machine spindle, faces have 1mm (.039") clearance.

PULLSTUD BOLTS

Tensile Strength Improved By Utilizing Tool Steel (H13).

Tool holders may be pulled out of the machine spindle at high speeds due to strong centrifugal forces. High tensile strength pullstuds are recommended to protect against this possibility.

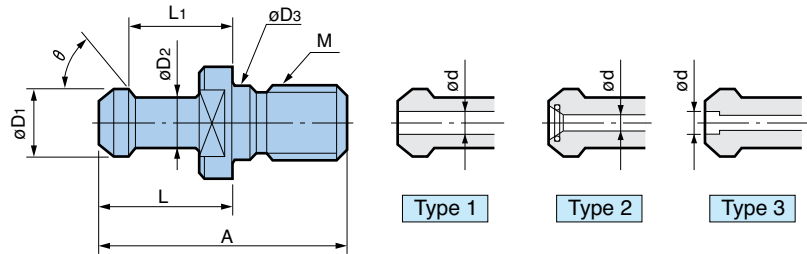

Spindle	Model	ϕD_1	ϕD_2	ϕD_3	A	L	L_1	θ	M	Hole Type	ϕd	Standard or Machine Make
CAT40	P40T-1CH	.591	.394	-	2.126	1.266	.990	45°	5/8"-11	1	.118	TOYODA
	P40T-1C1H			.641	2.250					2		
	P40T-2CH	.591	.394	-	2.126	1.266	.990	60°		1	.118	
	PVD40CH1	.748	.551	.641	2.008	1.024	.787	75°		1	.276	KITAMURA
	40PCH	.748	.551	.641	2.126	1.029	.793	75°		1	.276	
	PMO40C	.748	.551	-	1.887	1.029	.793	75°		2	.276	MORI SEIKI
	POM40CF	.591	.394	-	2.244	1.266	.990	90°		None	-	MORI SEIKI
	PYN40C	.740	.490	.641	1.500	.640	.440	45°		1	.276	MAZAK
CAT50	P50T-1CH	.906	.669	-	3.080	1.780	1.386	45°	1"-8	1	.315	MITSUBISHI
	P50T-1CH4			3.346	1.771	1.377	2			.236		
	P50T-2C	.906	.669	-	3.346	1.780	1.386	60°		None	-	
	P50T-2CH				3.071	1.771	1.377			1	.157	SNK
	P50T-2CH2				3.346	1.771	1.377			1	.157	SNK
	P50T-2CH11	1.102	.826	-	2.902	1.377	.984	75°		2	.236	OKUMA HOWA
	PVD50CH1				1.031	2.919	1.344			.990	1	.236
	PVD50CH2	.906	.669	-	3.346	1.780	1.386	90°		1	.452	MORI SEIKI
	POM50CH1				2	.315	MORI SEIKI					
	POM50CF	None	-	MORI SEIKI								
	PYN50C	1.140	.820	1.031	2.303	1.000	.700	45°		3	.629	MAZAK
	PMK50CMGH	1.102	.827	-	2.598	1.346	.992	75°		1	.394	MATSUURA
BT30	30PMG	.472	.315	.492	1.709	.921	.724	75°	M12P1.75	None	-	JIS
	30PMGH									1	.157	KITAMURA
	P30T-1MG	.433	.276	.492	1.693	.906	.709	45°		None	-	MAS-1
	P30T-1MGH									1	.098	ENSHU
	P30T-2MG	.433	.276	.492	1.693	.906	.709	60°		None	-	MAS-2
	P30T-2MGH									1	.098	ENSHU
	P30T-2MGH3									.295		BROTHER
	30P-1MGH	.433	.315	.492	1.693	.906	.709	45°		1	.157	ENSHU
PMO30MG	.276								2	.098	MORI SEIKI	
BT40	40P	.748	.551	.669	2.126	1.142	.906	75°	M16P2.0	None	-	JIS
	40PH									1	.276	MAKINO
	40PH2									None	-	MAS-1
	P40T-1	.591	.394	.669	2.362	1.378	1.102	45°		1	.118	OKUMA HOWA
	P40T-1H									2		
	P40T-1H4									1	.157	MAKINO
	P40T-1H7									None	-	MAS-2
	P40T-2	.591	.394	.669	2.362	1.378	1.102	60°		1	.118	
	P40T-2H									None	-	MITSUI SEIKI
	MP40	.591	.394	.669	1.969	.984	.709	90°		2	.275	MORI SEIKI
	PMO40	.748	.551		2.126	1.141	.906	75°		None	-	MORI SEIKI
	POM40F	.591	.394		2.362	1.378	1.102	90°		None	-	MORI SEIKI
	PYN40	.740	.490		1.736	.752	.552	45°		1	.276	MAZAK

1. Machine tool builders have used many various shapes and sizes of retention knobs. The use of the incorrect knob may result in injury or property damage for your machining center.

CLEANER SERIES

SPINDLE CLEANER

Keeps the spindle of your machine absolutely clean.



Model	Taper Size
20.580.230	30
20.580.240	40
20.580.250	50

TOOLING CLEANER

Tool Shank cleaner enhances the repeatability to the machine spindle.
Easy cleaning of the taper and face in a single action.

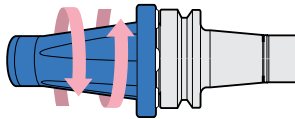
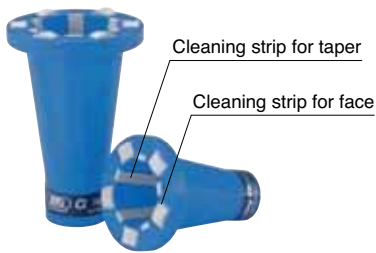

Model	Shank Size
SCE-30	BBT30
SCE-40	BCV40/BBT40

TAPER CLEANER

For cleaning the internal collet taper.

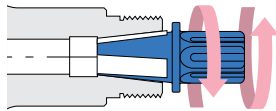

For Mega Micro Chuck

Model	Body
SC-NBC3S	MEGA3S
SC-NBC4S	MEGA4S
SC-NBC6S	MEGA6S

For Mega E Chuck

Model	Body
SC-MEC6	MEGA6E
SC-MEC8	MEGA8E
SC-MEC10	MEGA10E
SC-MEC13	MEGA13E

For Mega New Baby Chuck

Model	Body
SC-NBC6	MEGA6N
SC-NBC8	MEGA8N
SC-NBC10	MEGA10N
SC-NBC13	MEGA13N
SC-NBC16	MEGA16N
SC-NBC20	MEGA20N

For ER Collet Chuck

Model	Body
SC-MER11	ER11
SC-MER16	ER16
SC-MER20	ER20
SC-MER25	ER25
SC-MER32	ER32

WIPER CLEANER

For cleaning the bore of shrink fit holders and hydraulic chucks before tool insertion.

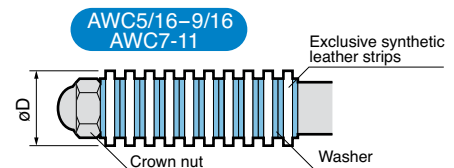
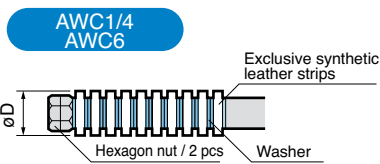

Inch Style

Model	AWC1/4	AWC5/16	AWC3/8	AWC7/16	AWC1/2	AWC9/16
øD (in)	.250	.312	.375	.437	.500	.562

Metric Style

Model	AWC6	AWC7	AWC8	AWC9	AWC10	AWC11	AWC12
øD (mm)	6	7	8	9	10	11	12

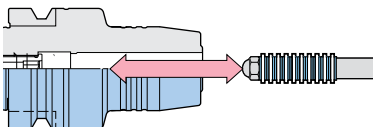

MEGA SYNCHRO TAPPING HOLDER

NEW

For Mega Synchro Tapping Holder, please refer to catalog

No. 163

Compensates for synchronization errors during rigid tapping

License **EMUGE**

BIG-PLUS
SPINDLE SYSTEM PAT.
DUAL CONTACT
US Patent No. 5352073

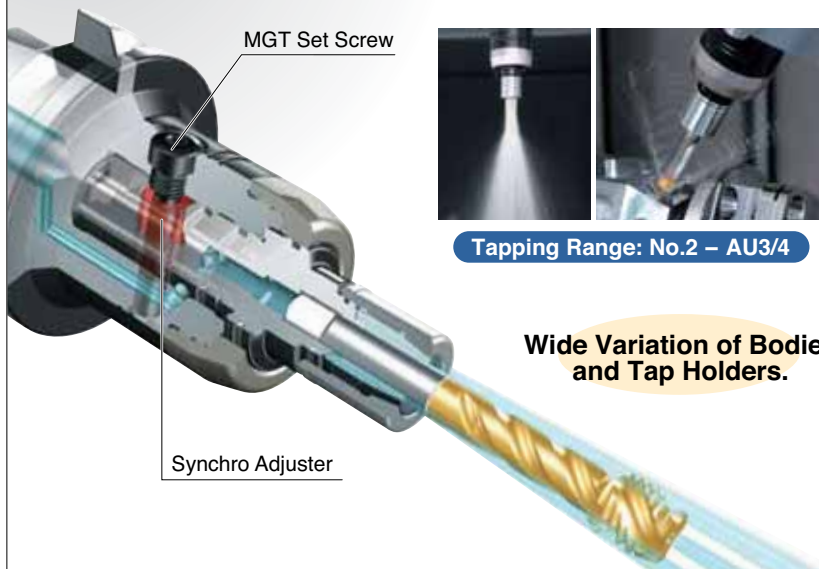

Improves thread quality and tool life by reducing thrust loads caused by synchronization errors up to 90%.

Comparison of Surface Finish

● Spiral Tap (No.10 - 24 Material: 4130)

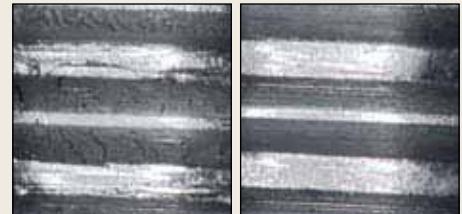

Collet Chuck

BIG MEGA SYNCHRO

AIR POWER SPINDLE

For Air Power Spindle, please refer to catalog

No. 142



Ultra high-speed and precision Micro-Machining, even on existing machining centers.

New advancement and capabilities in Micro-Machining

BIG-PLUS
SPINDLE SYSTEM PAT.
DUAL CONTACT
US Patent No. 5352073

Extended Tool Life

Drilling stainless steel with $\phi.020$ " carbide drill

Tool life: **500 holes**

With Machining Center
12,000 RPM
60 sec./hole



Material: Stainless steel

**Drastically extended tool life!
Reduced machining time by 1/3!**

Tool life: **1,200 holes**

With Air Power Spindle
50,000 RPM
20 sec./hole

HIGH SPINDLE

For High Spindle, please refer to catalog

No. 302

Achieve High Speed Milling

BIG-PLUS
SPINDLE SYSTEM PAT.
DUAL CONTACT
US Patent No. 5352073



High Spindle improves drilling and end milling performance on existing machines by multiplying the spindle speed 4, 5, or 6 times.

ANGLE HEAD

For Angle Head, please refer to catalog

No. 302

Wide range of compact heads suitable for all kinds of applications

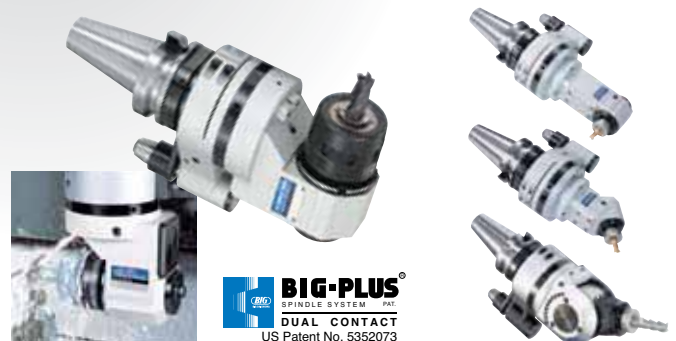

BIG-PLUS
SPINDLE SYSTEM PAT.
DUAL CONTACT
US Patent No. 5352073

Modern Facilities for High Quality Production



MEGA Technical Center



Awaji Factory No. 2



Awaji Factory No. 3



Awaji Factory No. 4



Osaka Factory



Awaji Factory No. 1



Awaji Factory No. 5

BIG BIG COROMANT CAPTO BIG DAISHOWA

The modular tooling system for turning and rotating tool holder applications.

MTCs[®]

(Machining & Turning Centers)



BIG HSK TOOLING SYSTEM BIG DAISHOWA

Ultra precision tooling system offered in a wide variety of configurations.

HSK-A40, A50, A63, A100

HSK-E25, E32, E40, E50

HSK-F63



BIG KAISER[®] PRECISION TOOLING INC.

641 Fargo Ave., Elk Grove Village, IL 60007

We are moving to a larger facility. Please use address below as of 11/09.

2600 Huntington Blvd., Hoffman Estates, IL 60192

Tel: 847.228.7660 • Fax: 847.228.0881

web: www.bigkaiser.com • e-mail: bigkaiser@bigkaiser.com

CATALOG No.EXi48-4-1009-3